

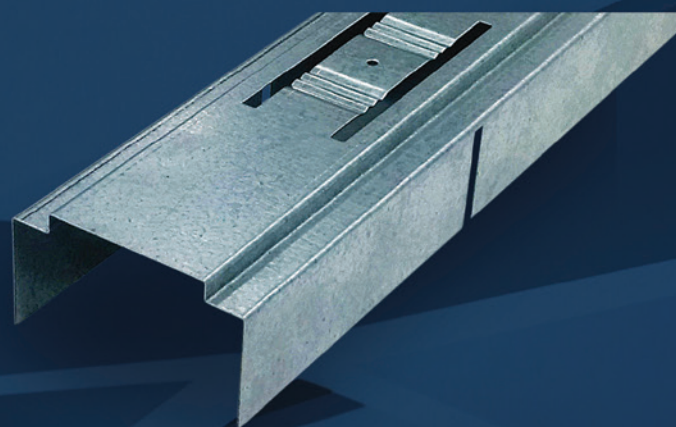

VORTEX

HIGH PERFORMANCE FRAMING SYSTEM

SKYSCRAPERS HIGH WIND LOCATIONS EXTREME TEMPERATURES



LEADERS IN INNOVATIVE BUILDING PRODUCTS



The most important evolution for internal wall construction in 50 years

Modern tall buildings often experience loud, uncontrolled 'creaking' noises which emanate from the internal wall structure. Through extensive research, Studco has developed a method for eliminating the stress and tension within the wall system that is the cause of the noise annoyance.

Revolutionising the way internal walls are constructed; Vortex Wall System from Studco is a breakthrough high-performing internal wall system that improves the behaviour of the wall structure in modern buildings.

Committed to best practice through ISO 9001 and ISO 14001 certified Quality and Environmental Management Systems; Studco Vortex conforms to all relevant Australian Standards and supports compliance to the Building Code of Australia.

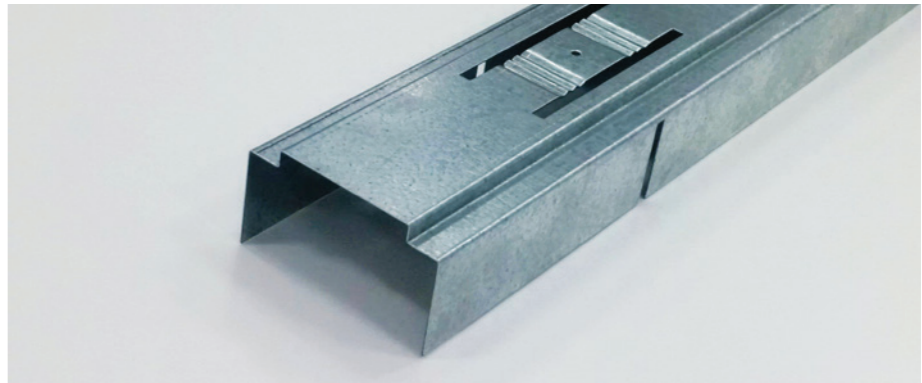

Studco Vortex segmented rebated track

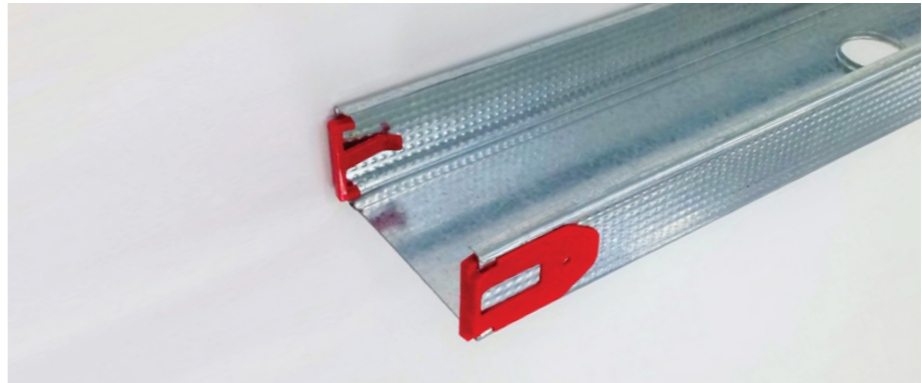

Studco Vortex stud isolation clips

VORTEX
HIGH PERFORMANCE FRAMING SYSTEM
SKYSCRAPERS HIGH WIND LOCATIONS EXTREME TEMPERATURES

Studco Vortex System

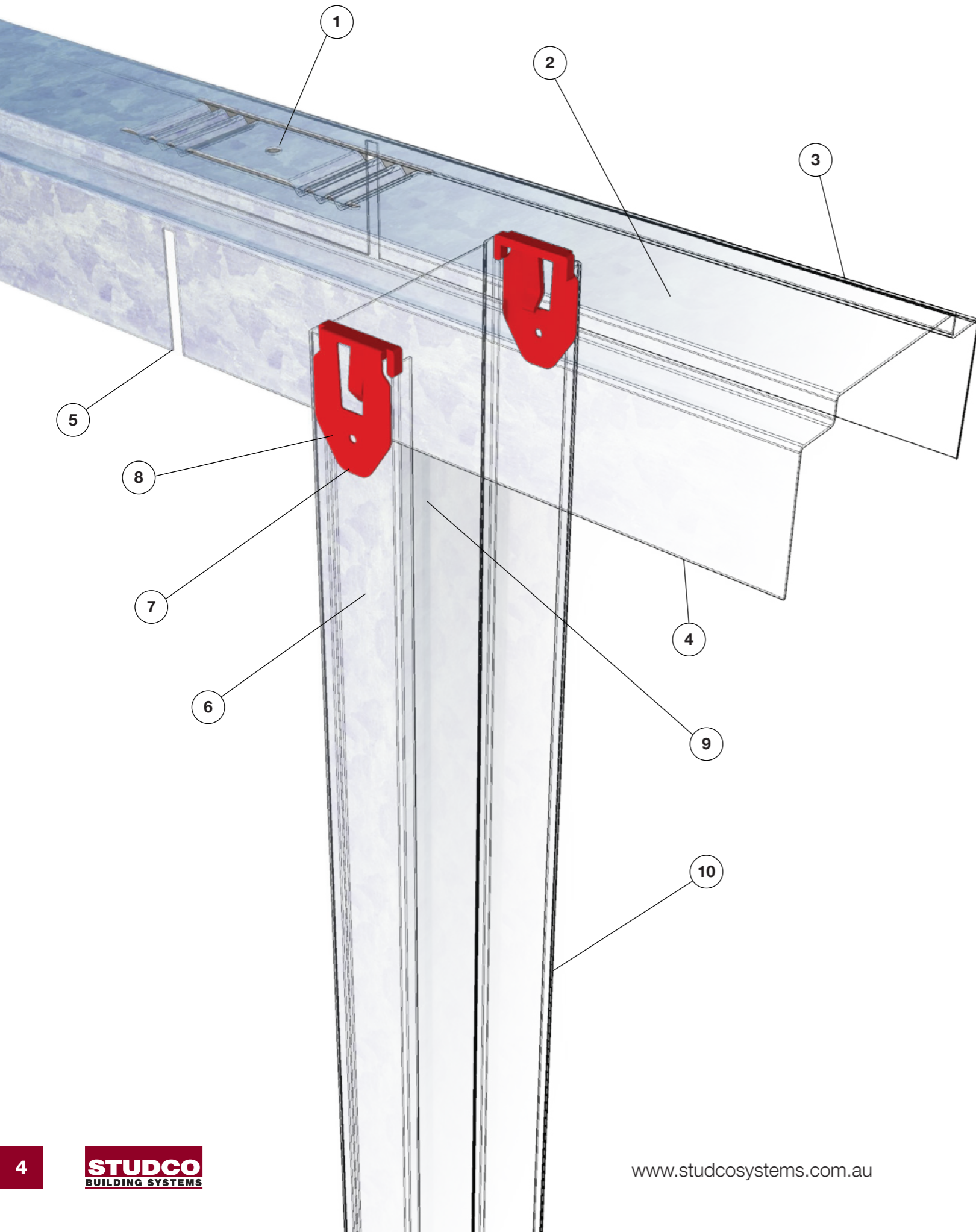

System Benefits

The patented Studco Vortex High Performance Framing System is the only fit-for-purpose internal, lightweight steel framing system that has been specifically engineered to address the variable surface elements of modern concrete structures and the dynamic external forces experienced by tall buildings.

Studco Vortex High Performance Framing System is the most reliable and practical solution for addressing the root cause of noise annoyance and is widely accepted in tall building construction as a best practice methodology.

Fixing Tab

- 1 Allows 100% positive fixing to substrate on uneven surfaces. Concertina zone is pre-stressed to limit tension and deformation of the track.

Rigid Beam

- 2 The Studco Vortex top track profile has a full-length rebated pan that increases stiffness and resists buckling forces, to ensure profile straightness and restrict them members following undulating concrete surfaces.

Wide Range of Applications

- 3 Suitable for use in all internal wall applications, even where vertical deflection is present and can be used at head and base of wall. Also used for fire-rated walls and acoustic walls.

Service Cutaways

- 4 No loss of system strength when the track flanges are cut to allow for the passage of services such as pipes and ducts.

Anti-Tension Kerfs

- 5 Strain-relief kerfs provide a secondary measure to limit deformation of the flanges where the substrate is extremely uneven. This disallows the transfer of tension along the profile length.

100% Isolation

- 6 Stud isolation clip completely disallows metal-on-metal contact at the stud to track connection. Can also be used as a locator or shoulder in other wall construction elements.

Superior Wear Resistance

- 7 High density, hard wearing, low friction polymer material with fire-retardant properties, designed to last the lifetime of the building even in the harshest abrasive conditions.

Quality Control

- 8 Lower portion of the red isolation clip is highly visible and protrudes past the track flange for quick visual confirmation of installation and provides an easy way to check overall stud length.

Multiple Uses

- 9 Isolation clips can also be at the base of wall studs, as locators for doors jamb studs, furring channels and ceiling wall track sections.

No Noggings

- 10 High strength, deep-leg track improves resistance to axial load removing the need for noggings in many wall configurations.

Research

Wind Studies

Studco led a collaborative research project into noise annoyance in tall buildings in conjunction with Deakin University, Multiplex and PKA Acoustic consultants. The Studco Vortex Wall System evolved as a solution over a two year study period which analysed data from global wind studies, field investigations and audio recordings of tall buildings with known problems. Prototype systems were then laboratory tested by Deakin University and the final design was installed in skyscrapers and tested.

Initial findings singled out that high wind events were a common cause for noise annoyance in high-rise buildings and as a result of this, it became a primary focus for the research conducted.

Amongst built up cities with a large concentration of high-rise buildings, a phenomenon known as vortex shedding occurs. This natural effect is caused by wind as it flows around buildings in an oscillating pattern causing vibrations across the building structure.

Further analysis of multiple wind tunnel test reports from highly populated cities uncovered that this was linked closely to vibration and tension related noise.

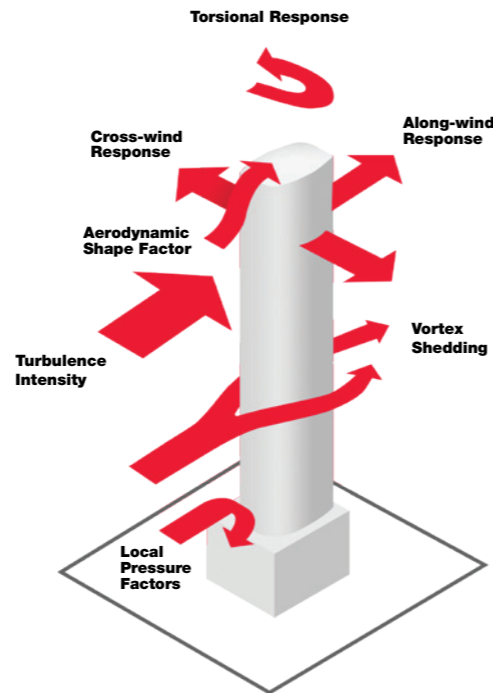

Field Investigations

Inspection of concrete substrate surfaces unveiled several issues with the wall fixing interface, including misaligned formwork, residue concrete and debris attached to the concrete. In some cases, the concrete surface had ridges and obstructions up to 10mm high and over a relatively short distance, the level of the surface varied 10-20mm, providing an uneven surface for internal walls to be fixed to the structure.

By accessing ceiling and wall cavities, several buildings with known issues were investigated. This included employing infrared cameras to locate the source of movement and possible causes of noise annoyance. Numerous construction projects were monitored over the two-year research period to gain an insight into common installation practices. This provided an understanding of the on-site constraints that confront internal wall installers.



Misaligned formwork was identified as a contributing factor to tension in internal framing.



Formwork residue and concrete debris often present uneven fixing surfaces which are not made good prior to wall installation.

Solution Development

Data Analysis

For several months acoustic recording devices were installed into buildings with reported problems to capture the noises a resident would typically experience. To determine the exact source of the noise annoyance, walls and ceilings were removed in existing buildings and acoustic source localisation methods were employed using a dispersed microphone array.

Analysis by PKA Acoustics identified each individual noise and its location within the targeted building structure. This process singled out the noise emitting from the internal wall framing and was cross referenced against wind data recorded from the Australian Bureau of Meteorology.

Analysis concluded that noise annoyance occurred mostly during high wind events. The high winds induce aggressive vibration in the building structure, generating a creaking noise. Due to the tension caused by the uneven concrete substrate this noise has been measured at levels reaching 58db.

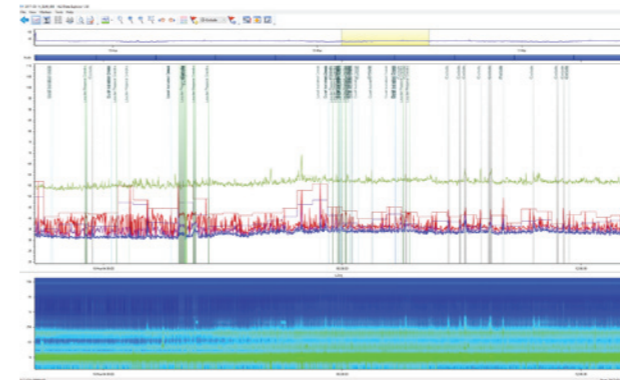

Sound recording analysis identifying the various noises experienced by a high-rise apartment resident.

Product Development

From the evidence discovered during Studco's studies, it became clear that new problems require new thinking. Using 3D modelling and finite element analysis; the Studco Research & Innovation Team collaborated to produce a practical solution to noise annoyance in internal walls. Initial digital prototypes were tested through construction simulations to verify the performance in high tension applications.

Emphasis was placed on removing the tension from the metal components in the wall system and isolating metal-on-metal connections, whilst still achieving the desired structural, acoustic and fire rating outcomes of the wall system. The final prototypes were subjected to our verification processes which included critical appraisal from stakeholders across the full spectrum of the construction industry.

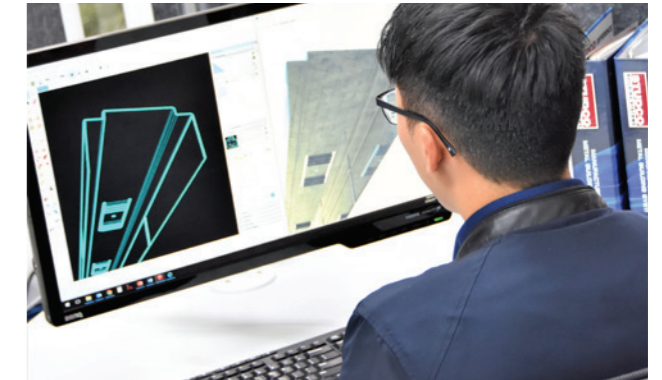

New products evolved from the 3D modelling process used by Studco's design team.

Testing

Computer Simulations

Using finite element analysis to identify component displacements, strains, and stresses under internal and external loads, Deakin University benchmarked the Studco Vortex system against other wall systems on the market.

This stimulation was based on a wall installation fixed to a concrete substrate with an undulating surface of +/- 3mm, significantly less than witnessed in the field.

This testing identified both extensive elastic and plastic deformation across the traditional system.

The images below displays a large amount of tension and deformation in traditional steel sections. In contrast, the Studco Vortex section shows only a small amount of deformation around the designed for purpose pre-stressed fixing tabs.

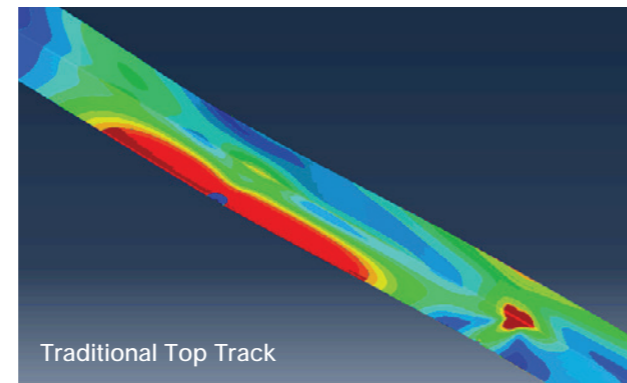
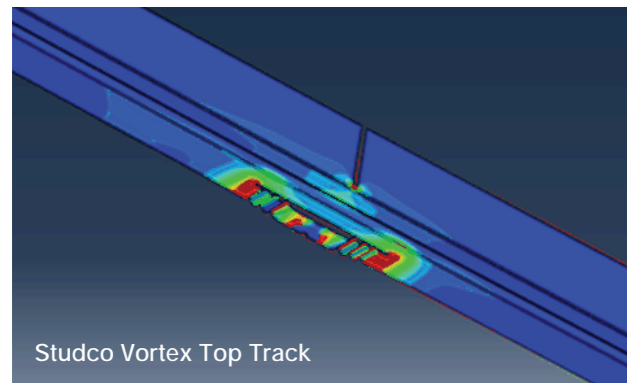

Finite numerical testing conducted by Deakin University 11 June 2016



Structural Lab Testing

Verifying the results of the FEA process, Deakin University conducted structural testing of traditional wall systems against the Studco Vortex system. This displayed comparable results to the FEA as the traditional system displayed extreme deformation across the length of the metal profiles.

Results show the unyielding rigidity of the Studco Vortex Wall System stood out, when evaluating the two tested samples. This is important to modern high-rise buildings as deformation of the profile introduces stress into the system and increases the likelihood of generating noise and friction in the internal framing system.

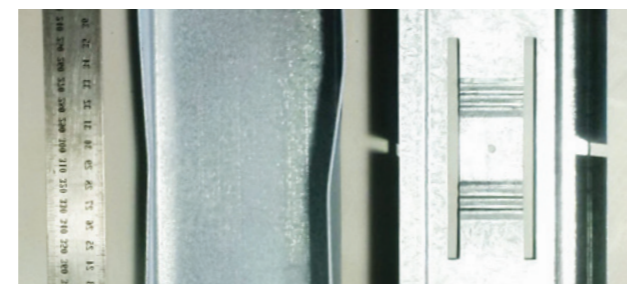
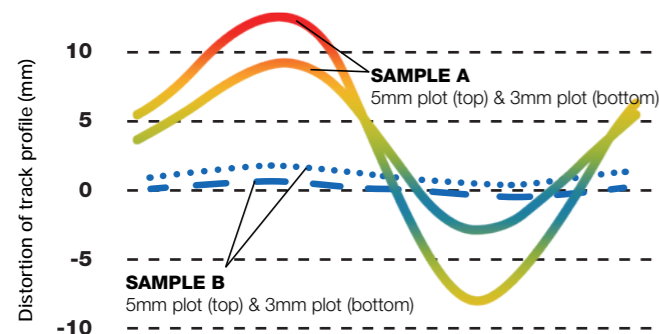

Sample A (Traditional)

Sample B (Vortex)

Test conducted by Deakin University (ref.22052016) in Geelong, Australia Aug 2016

Results

Trial Installation

The new Studco Vortex wall system underwent the ultimate test when it was installed in apartments within a 250 metre tall building which had known noise annoyance issues. Initially, sound recording devices were placed within the apartment for three months to capture the noises experienced within the living space. Then the existing walls were removed and replaced with the new Studco

Vortex wall system, followed by a further three month period of recording the noises in the apartment. Using wind speed recorders placed on the building to align similar high wind events, the before and after results of the sound recordings were then compared and conclusively proved that the Studco's new system had removed the noise annoyance from the wall framing.

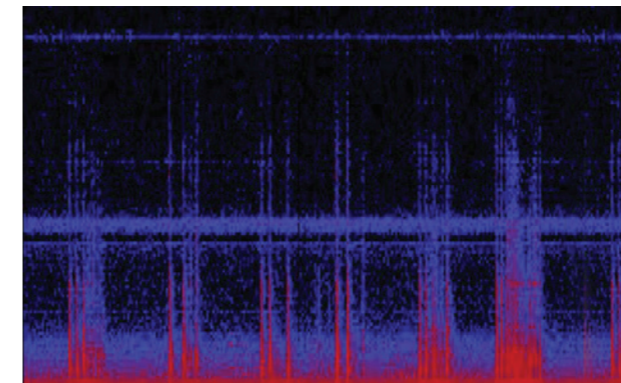

Audible creaking noise up to 58dB with walls constructed from a traditional wall system.

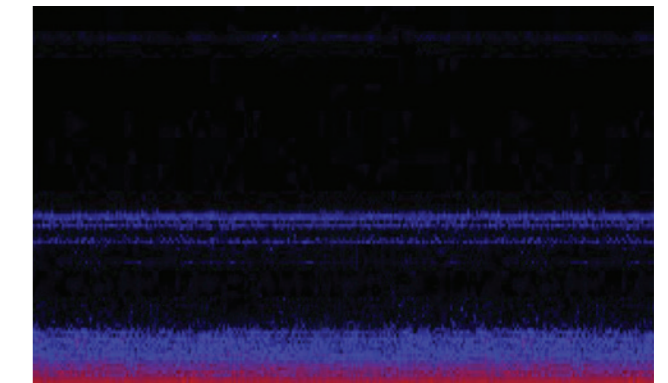

After walls were rebuilt from Studco Vortex wall system, only normal ambient noise is audible.

Independent tests conducted by Pka Acoustics (Ref.219159) in Melbourne, Australia Nov 2016 - Mar 2017



Studco Vortex System

64mm

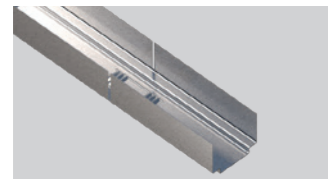

SEGMENTED REBATE TRACK

Part No.	SEGMENTED REBATE TRACK	Length mm	Sub Pack	Stock Pack
SRT6475-30	Studco Vortex 64 x 0.75 BMT rebate track	3000	10	100

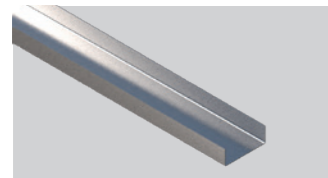

TRACK

Part No.	TRACK	Length mm	Sub Pack	Stock Pack
T6450H-30	Studco 64 x 0.50 track 3.0m	3000	10	100
T6475H-30	Studco 64 x 0.75 track 3.0m	3000	10	100

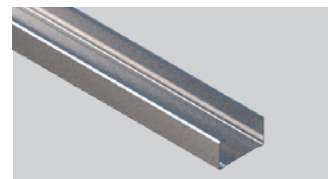

STEEL WALL STUD

Part No.	STEEL WALL STUD	Length mm	Sub Pack	Stock Pack
S6450-24	Studco 64 x 0.50 BMT wall stud	2400	10	100
S6450-27	Studco 64 x 0.50 BMT wall stud	2700	10	100
S6450-275	Studco 64 x 0.50 BMT wall stud	2750	10	100
S6450-28	Studco 64 x 0.50 BMT wall stud	2800	10	100
S6450-30	Studco 64 x 0.50 BMT wall stud	3000	10	100
S6450-33	Studco 64 x 0.50 BMT wall stud	3300	10	100
S6450-36	Studco 64 x 0.50 BMT wall stud	3600	10	100
S6450-42	Studco 64 x 0.50 BMT wall stud	4200	10	100



STUD ISOLATION CLIP

Part No.	STEEL WALL STUD	Length mm	Sub Pack	Stock Pack
S6475-24	Studco 64 x 0.75 BMT wall stud	2400	10	100
S6475-27	Studco 64 x 0.75 BMT wall stud	2700	10	100
S6475-30	Studco 64 x 0.75 BMT wall stud	3000	10	100
S6475-36	Studco 64 x 0.75 BMT wall stud	3600	10	100
S6475-42	Studco 64 x 0.75 BMT wall stud	4200	10	100
S6475-48	Studco 64 x 0.75 BMT wall stud	4800	10	100
S6475-60	Studco 64 x 0.75 BMT wall stud	6000	10	100

Part No.	STUD ISOLATION CLIP	Sub Pack	Stock Pack
M120	Studco Vortex stud isolation clip	10	50

Studco Vortex System

92mm

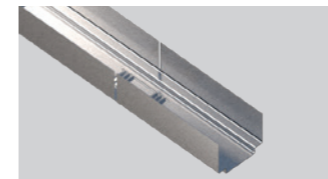

SEGMENTED REBATE TRACK

Part No.	SEGMENTED REBATE TRACK	Length mm	Sub Pack	Stock Pack
SRT9275-30	Studco Vortex 92 x 0.75 BMT rebate track	3000	10	100

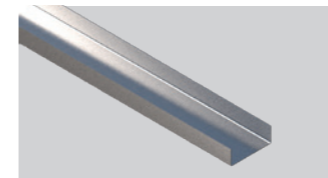

TRACK

Part No.	TRACK	Length mm	Sub Pack	Stock Pack
T9255H-30	Studco 92 x 0.55 track 3.0m	3000	10	100
T9275H-30	Studco 92 x 0.75 track 3.0m	3000	10	100

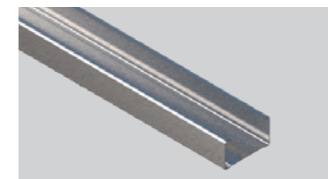

STEEL WALL STUD

Part No.	STEEL WALL STUD	Length mm	Sub Pack	Stock Pack
S9250-24	Studco 92 x 0.50 BMT wall stud	2400	10	100
S9250-27	Studco 92 x 0.50 BMT wall stud	2700	10	100
S9250-275	Studco 92 x 0.50 BMT wall stud	2750	10	100
S9250-30	Studco 92 x 0.50 BMT wall stud	3000	10	100
S9250-33	Studco 92 x 0.50 BMT wall stud	3300	10	100
S9250-36	Studco 92 x 0.50 BMT wall stud	3600	10	100
S9250-42	Studco 92 x 0.50 BMT wall stud	4200	10	100
S9250-48	Studco 92 x 0.50 BMT wall stud	4800	10	100



STUD ISOLATION CLIP

Part No.	STEEL WALL STUD	Length mm	Sub Pack	Stock Pack
S9275-24	Studco 92 x 0.75 BMT wall stud	2400	10	100
S9275-27	Studco 92 x 0.75 BMT wall stud	2700	10	100
S9275-30	Studco 92 x 0.75 BMT wall stud	3000	10	100
S9275-36	Studco 92 x 0.75 BMT wall stud	3600	10	100
S9275-42	Studco 92 x 0.75 BMT wall stud	4200	10	100
S9275-48	Studco 92 x 0.75 BMT wall stud	4800	10	100
S9275-60	Studco 92 x 0.75 BMT wall stud	6000	10	100

Part No.	STUD ISOLATION CLIP	Sub Pack	Stock Pack
M120	Studco Vortex stud isolation clip	10	50

Studco Australia Pty Ltd

130 - 140 Merrindale Drive
Croydon South, VIC 3136
Phone: 1300 255 255
Email: sales@studcosystems.au

Studco Building Systems US LLC

1700 Boulder Industrial Parkway
Webster, NY 14850
Phone: 1 888 399 5262
Email: sales@studcosystems.com

Studco Building Systems UK

Unit 10 Carnforth Business Park
Oakwood Way, Carnforth LA9FD
Phone: 020 3488 9655
Email: sales@studcosystems.co.uk



www.studcosystems.com.au