



A flexible solution for every application

The modular Rheem on-tap series provides a beautifully efficient solution, regardless of your needs and application. Boiling, chilled and filtered water combinations can be specified with the intelligent Rheem on-tap series.

And because it's from Rheem, you know it's backed by our nation-wide service and support network, as well as our reputation for quality and thoughtful design.

Designed in partnership with architects, interior designers and hydraulic engineers, the Rheem on-tap series provides clear cut advantages in the areas of aesthetics, usability, performance, efficiency and installation. Beauty. And brains.

INSTALL A RHEEM®

Rheem on-tap series installation and specification requirements

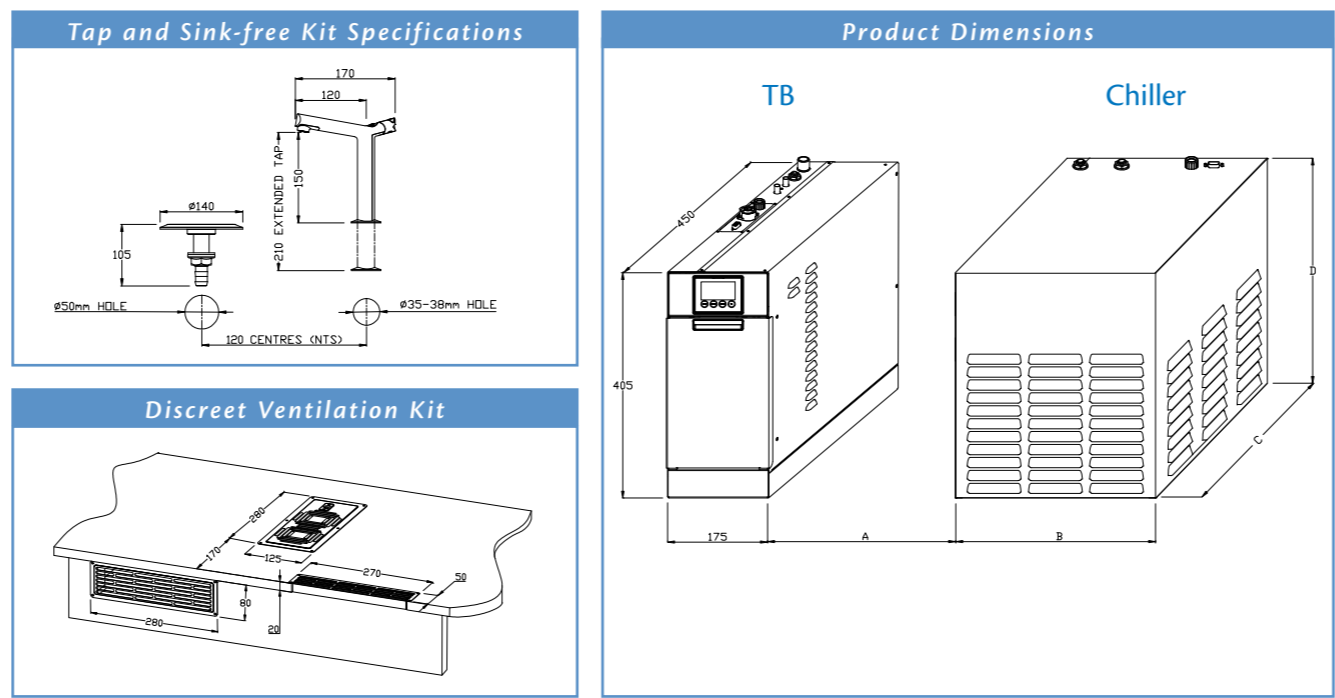

Rheem on-tap series		TB		Chiller			
		Filtered Boiling & Drinking Water		Pumped		Push through	
Specifications	Model	TB3	TB5	CHP3	CHP6	CH3	CH6
Specification Code	With Filter	740003F	740003F	290254	290255	290250	290251
	WO Filter	7400003	7400005				
Capacity	Litres (L)	3	5	3	6	3	6
Cups Initial	Cups ¹	24	31	15	30	15	30
Litres Initial	Litres (L)	4	5	3	6	3	6
Cups One Hour	L/hr	24	28	25	34	25	34
	Cups ¹ per hr	145	170	125	175	125	175
Approx Weight Empty	kg	12	12	13	15	13	16
Approx Weight Full	kg	18	18	16	21	16	22
Minimum Water Supply Pressure	kPa	100	100	100	100	250	250
Maximum Water Supply Pressure	kPa	1000	1000	1000	1000	1000	1000
Input	kW	1.5	1.8	0.28	0.32	0.28	0.38
Electrical Connections	Supplied with 10 Amp 3 Pin Plug and Flex			Powered by TB		Powered by TB	
Plumbing Connections	Cold Water	½" BSPF	½" BSPF	Inlet – 1/4" JG		1/4" John Guest	
				Outlet – Silicone			
Dimensions							
B	Width	mm	175	175	285	285	300
C	Depth	mm	450	450	430	450	410
D	Height	mm	405	405	360	405	320
A	Clearance	mm	50mm MIN	50mm MIN	50mm MIN	50mm MIN	150mm MIN
Accessories							
	Part Number						
5 Micron Filter Kit	317327	-	-				
Sink-free Kit	317453	Optional	Optional				
Discreet Ventilation Kit	317255	-	-	Optional	Optional	Optional	Optional

Rheem on-tap series Combination Models – Specification Code		
Code	Includes	Description
TB3CHP3	740003F + 290254	3L Boiling and 3L Chilled combination 145/125 Cups
TB3CHP6	740003F + 290255	3L Boiling and 6L Chilled combination 145/175 Cups
TB5CHP3	740005F + 290254	5L Boiling and 3L Chilled combination 170/125 Cups
TB5CHP6	740005F + 290255	5L Boiling and 6L Chilled combination 170/175 Cups

1 Cup size 170ml, glass size for chilled water 200ml. Materials and specifications are subject to change without notice due to ongoing product improvements. *Rheem is a registered Trade Mark of Rheem Australia Pty Ltd.



Quality System
Quality Endorsed Company
ISO 9001
Lic. QEC 14766
SAI Global



WaterMark
AS 3498
Lic. WMKA0177
SAI Global

WARRANTY
2 years warranty for parts and labour plus 5 years for tanks.
Conditions apply. For full warranty details please contact Rheem or see installation manual.

Rheem Australia
www.rheem.com.au
Sales 132 552
Service 131 031



Quench your thirst for smarter design

INSTALL A RHEEM®



SAFETY LOCK REQUIRES TWO-FINGER OPERATION FOR BOILING WATER



READY AND FILTER LIGHTS ADVISE WHEN WATER IS BOILED OR WHEN FILTER REQUIRES REPLACING



QUALITY CHROME PLATED CAST METAL BODY FOR STYLE AND DURABILITY



DRIP-FREE DESIGN FOR CLEANER WORK AREAS



RUBBER TIPPED ACTIVATION LEVERS FEATURE MOMENTARY AND LOCK-ON POSITIONS TO ASSIST WITH FILLING INDIVIDUAL CUPS OR LARGE JUGS

Energy efficient

Users can set the 7 day programmable timer to suit their schedules and save energy when drinks are not required. Timer programming is simple and intuitive. Additionally a sleep mode automatically powers the unit down when it's not in use.



Filter out the taste of chlorine

The Rheem on-tap series has models with and without filters. When a filter is fitted it removes chlorine, taste and odours for a perfect drink of water or cup of tea. Fine dirt and sediment particles are removed while an advanced phosphate compound reduces costly lime-scale build-up.

The replaceable filter cartridge can be easily removed by a simple twist and pull of the bayonet fitting.

Perfectly chilled

Optional Rheem chillers are available for both the 3 litre and 6 litre models providing up to 175 glasses of chilled water per hour. Flexible, modular design ensures maximum use of under cupboard space. Optional Rheem chillers automatically mirror the timer and auto-shut off programming of the Rheem TB.



While under the counter the focus is all about performance and flexibility, above the counter the focus is style, safety and ease of use. The water dispenser for the Rheem on-tap series was designed in close consultation with architects and interior designers to look and feel beautiful, and be safe and simple to use.

Chilled Filtered Boiling



Intelligent design adds style and safety

INSTALL A RHEEM®



"Breakthrough technology delivers boiling water & reduces installation costs"

Filtered boiling and drinking water, on-tap

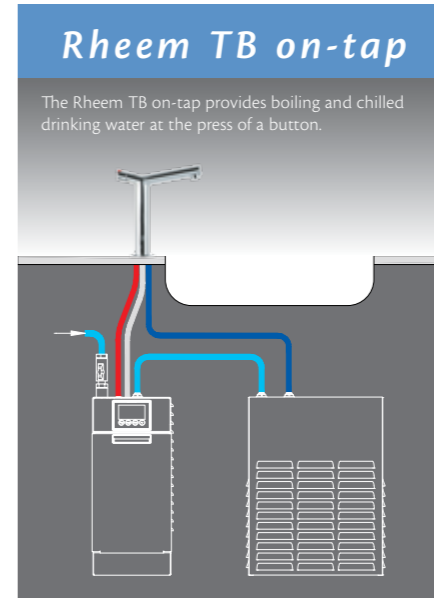

Rheem TB on-tap

The Rheem TB on-tap provides boiling and chilled drinking water at the press of a button.

When you need boiling water for tea or coffee and drinking water for a refreshing drink, the Rheem TB on-tap is the ideal fit for any small to medium sized office. The under counter TB cabinet is compact in size, requiring only a cold water connection and a standard power point.

Water may be filtered and, if desired, chilled water can be provided with the addition of the modular Rheem chiller unit.

- 3 AND 5 LITRE TB MODELS, DELIVER UP TO 170 CUPS OF BOILING WATER PER HOUR
- MODELS WITH A WATER FILTER, PROVIDE CLEANER DRINKING WATER AND IS EASY TO CHANGE
- BUILT-IN SAFE TRAY ELIMINATES NEED FOR SEPARATE TRAY AND DRAINAGE, ADDING PEACE OF MIND AND REDUCING INSTALLATION COSTS
- 7 DAY PROGRAMMABLE TIMER AND SLEEP MODE SAVES ENERGY AND MEETS BCA REQUIREMENTS
- OPTIONAL CHILLER UNIT IS MODULAR IN DESIGN TO MAXIMISE UNDER COUNTER SPACE



Accessories on-tap Sink-free Kit

Want to locate the dispenser in the boardroom or break-out room? The Rheem sink-free kit eliminates the need for a sink, allowing bench top mounting. A perfect complement to the tap design, the Rheem sink-free kit includes a drainage grate and tap extension to clear tall jugs and bottles.

Discreet Ventilation Kit

Ventilation is essential when installing a chiller. The only tell tale sign of the Rheem discreet ventilation kit is the stainless steel grill, low down on the kick plate. Instead of unsightly grills in cupboard doors, the Rheem fan, air intake and stainless steel exhaust grill are all housed discreetly at kick plate level. The fan draws power from the TB unit and saves energy by running only when required.

