



WOVEN IMAGE®

DESIGN DEPARTMENT - PRODUCT SPECIFICATION SHEET

DATE: 31.1.19

DESIGN NAME	Cellular
DESIGNER:	Woven Image
ORIGIN:	Australia
COLOURS:	27
WEAVE:	Non woven
COMPOSITION:	100% PET (60% recycled)
DIMENSIONS:	1158mm x 2380mm (+/- 2mm)
WEIGHT:	3.8 kg per panel
THICKNESS:	12mm +/- 7% (Echo Panel)

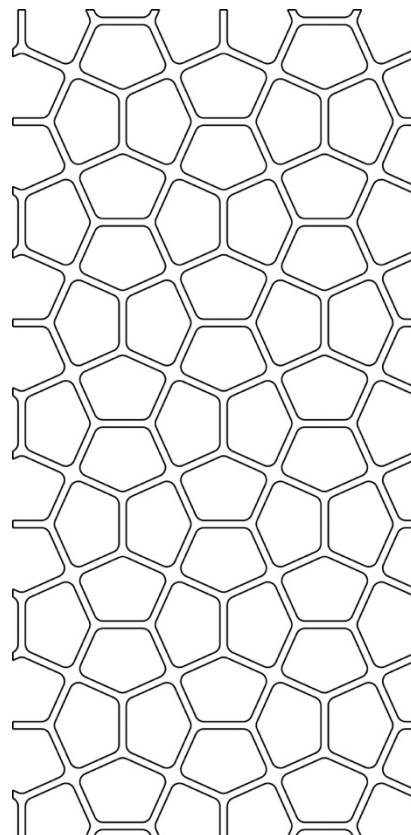



WOVEN IMAGE®

PERFORMANCE

COLOUR FASTNESS TO LIGHT:

ISO 105-B02-1994 Rating: 6-7

FIRE TEST:

EchoPanel® 12mm achieves:
AS 1530.3
ISO 9705: Group 1
GB8624 B1
BS EN 13501.1: Classification B-s1, d0

FABRIC CARE:

See additional care guide.
Blot excess spills from material quickly.
Wipe with a damp cloth.
Warning, avoid excessive amounts of water.

SOUND ABSORPTION:

EchoPanel® 12mm achieves:
AS ISO 354 – 2006
NRC Value: 0.35 (with no air gap)

VOC EMISSIONS:

ASTM D5116 Rate: < 0.02 mg/m²/hr (7 days)



ENVIRONMENTAL:

EchoPanel® achieves GreenTag Certification
GreenRate: Level A

INSTALLATION:

Prior to installation, ensure the surface area to which the tiles are going to be fixed is smooth, clean and free from dust or any other contaminants that may impede the installation.



USE:



WOVEN IMAGE®

DESIGN DEPARTMENT - PRODUCT SPECIFICATION SHEET

DATE: 31.1.19

DESIGN NAME	Penta
DESIGNER:	Woven Image
ORIGIN:	Australia
COLOURS:	27
QUANTITY:	10 tiles per box
COMPOSITION:	100% PET (60% recycled)
DIMENSIONS:	185mm (+/- 1mm) x 245mm (+/- 1mm) 25mm corner radius
WEIGHT:	2.28 kg/box of 10
THICKNESS:	12mm +/- 7%

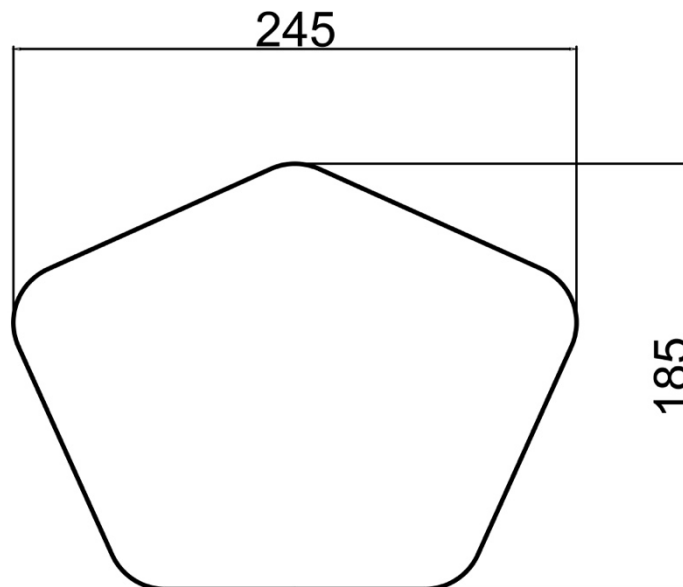

PERFORMANCE

COLOUR FASTNESS TO LIGHT:

ISO 105-B02-1994 Rating: 6-7

FIRE TEST:

EchoPanel® 12mm achieves:
AS 1530.3
ISO 9705: Group 1
GB8624 B1
BS EN 13501.1: Classification B-s1, d0

FABRIC CARE:

See additional care guide.
Blot excess spills from material quickly.
Wipe with a damp cloth.
Warning, avoid excessive amounts of water.

SOUND ABSORPTION:

EchoPanel® 12mm achieves:
AS ISO 354 – 2006
NRC Value: 0.35 (with no air gap)

VOC EMISSIONS:

ASTM D5116 Rate: < 0.02 mg/m²/hr (7 days)



ENVIRONMENTAL:

EchoPanel® achieves GreenTag Certification
GreenRate: Level A

INSTALLATION:

Prior to installation, ensure the surface area to which the tiles are going to be fixed is smooth, clean and free from dust or any other contaminants that may impede the installation.



USE: