



**ALSPEC SOLAIRE™ FIXED LOUVRES**

# Solaire™

*"...built on the back of Alspec's architectural systems knowledge, balancing the need for both form and function..."*

## Alspec Solaire™ Fixed Louvres

The Solaire™ range of self mating louvre fins has been developed to provide both Architects and Fabricators a flexible, yet simple solution to external solar control requirements that seamlessly integrate with Australia's unique architectural landscape. By utilising a range of self mating clip together blades and accessories, the Solaire™ product can be used as:

- Horizontal fins
- Vertical blades
- Window hoods

The Solaire™ range has been built on the back of Alspec's architectural systems knowledge, which balances the needs of both form and function. Alspec's design offers a robust solution that offers our customers an economical and flexible fabrication option.

With countless configurable sizes and aesthetic possibilities, the Solaire™ range is the perfect solution for your next residential or commercial project.





## Versatile Building Solution

### Environmentally Friendly

- 100% Recyclable Aluminium.
- Solaire™ Blades reduce direct sunlight and heat transfer.

### Elegant Smart Design

- Flexible fitting options to exceed market requirements.
- Available in a wide range of powder coated or anodised finishes.
- Innovative locking bar improves rigidity and "clip" strength.

### Built to Last

Aluminium will not rust, rot, crack or perish under Australia's harsh conditions.



# Fixing Options and Typical Configuration

Alspec has designed a wide range of extrusions to cover a multitude of design widths for both vertical and horizontal blade configurations for use in both commercial and residential applications.

Utilising recommended fixing methods to particular structures, Alspec Solaire™ fixed louvres can be configured in a myriad of different configurations.

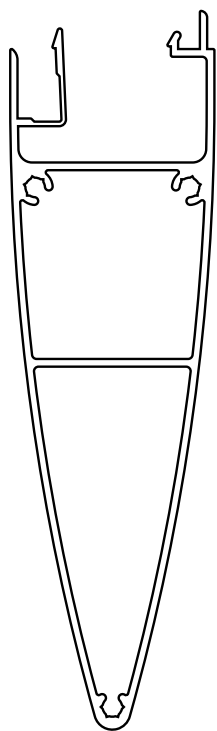

**LVE301**

150mm Self Mating Elliptical Louvre

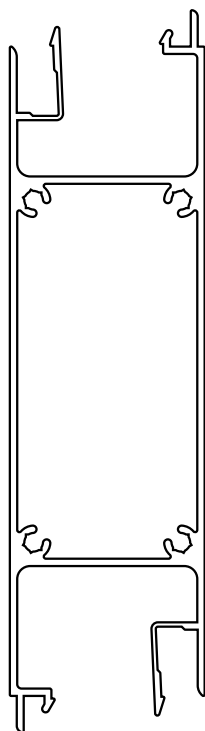

**LVE302**

150mm Self Mating Louvre

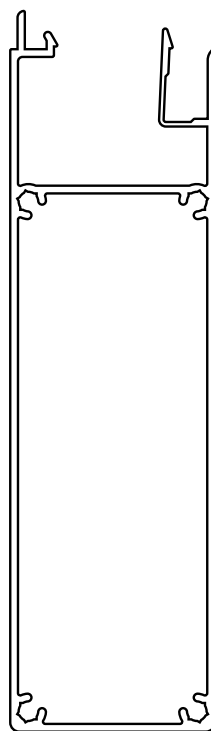

**LVE306**

150mm x 45 mm Self Mating Square Fin

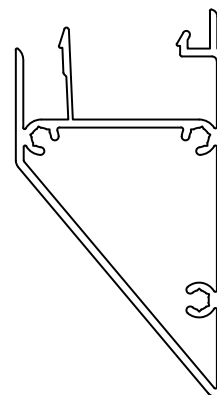

**LVE311**

Self Mating 45mm Bullnose Fin

**\*\*Not to Scale\*\***

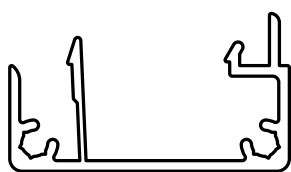

**LVE303**

17mm x 45 mm Self Mating Square Fin

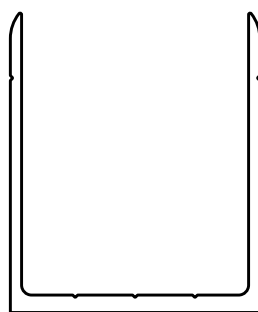

**LVE304**

45mm Louvre Channel

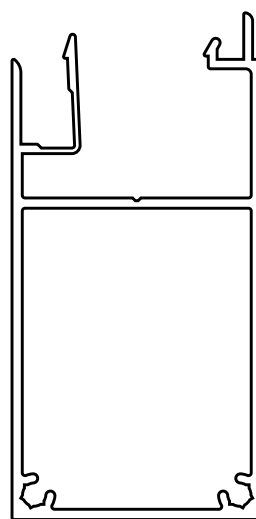

**LVE305**

83mm x 45 mm Self Mating Square Fin

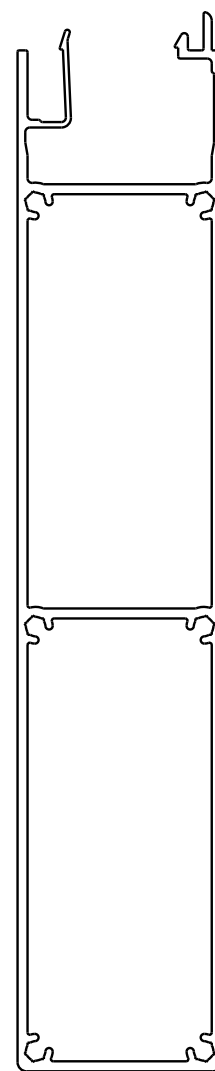

**LVE308**

225mm Self Mating Louvre

## Louvre Locking Bar

The Solaire Locking Bar ensures that the louvre sections do not unclip, improving structural integrity of the finished product.

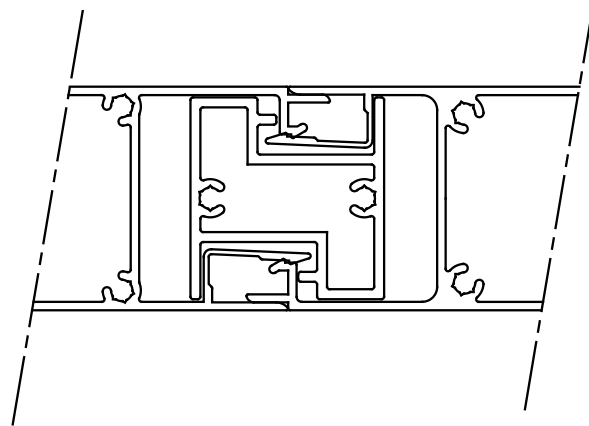

## Structural Fixing Options

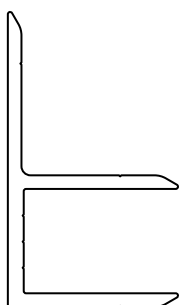

**LVB1**

Structural 45mm F Bracket

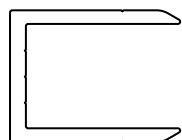

**LVB2**

Structural 45mm Channel

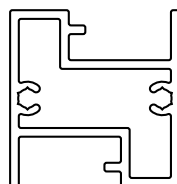

**LVB4**

Patented Locking Bar

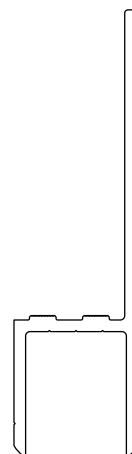

**LVB5**

45mm Louvre Bracket

## Potential Configurations

Finished Size	Component Configuration	Sections
100	83 + 17	LVE305 + LVE303
166	83 + 83	LVE305 + LVE305
167	150 + 17	LVE306 + LVE303
184	17 + 150 + 17	LVE303 + LVE302 + LVE303
233	150 + 83	LVE306 + LVE305
250	150 + 83 + 17	LVE302 + LVE303 + LVE305
300	150 + 150	LVE306 + LVE306
317	150 + 150 + 17	LVE306 + LVE302 + LVE303
334	17 + 150 + 150 + 17	LVE303 + LVE302 + LVE302 + LVE303
383	150 + 150 + 83	LVE306 + LVE302 + LVE305
450	225 + 225	LVE308 + LVE308



# Solaire Batten Range

Alspec's Solaire Batten range has been designed to offer a superior seamless aesthetic in both domestic and commercial facade, fencing and pergola applications.

The battens are available from a 50 x 50 through to a 200 x 50 configuration in simple seamless click together aluminium sections.

The Solaire batten range is available in a wide range of durable powder coating finishes including timber grain coatings.

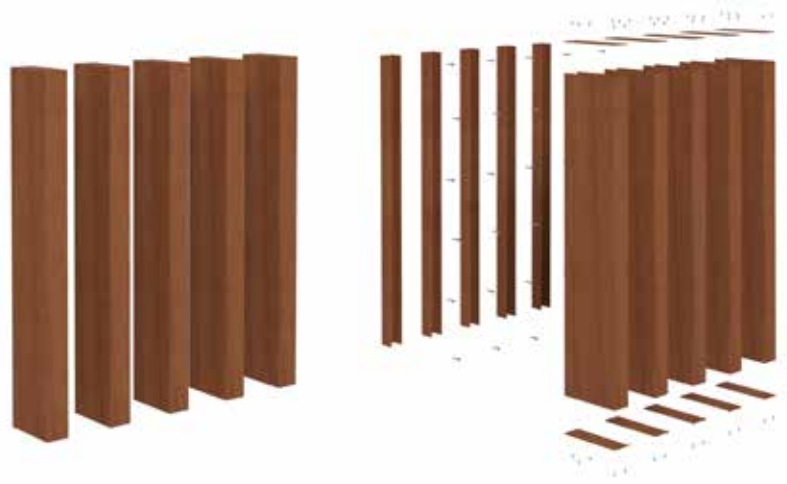

## Batten Options

**\*\*Not to Scale\*\***

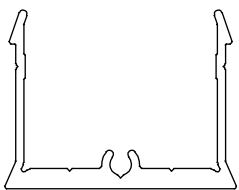

**LVE501**

50mm Batten Flush Infill

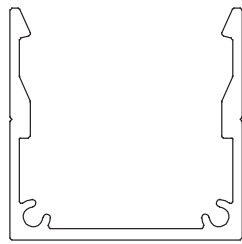

**LVE502**

50 x 50mm Batten

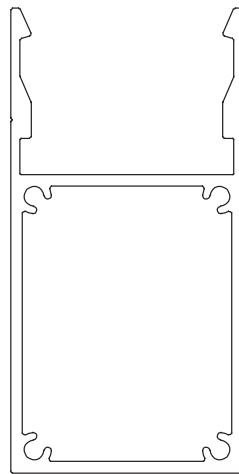

**LVE503**

100 x 50mm Batten

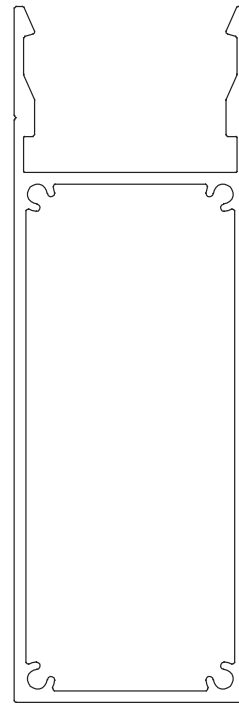

**LVE504**

150 x 50mm Batten

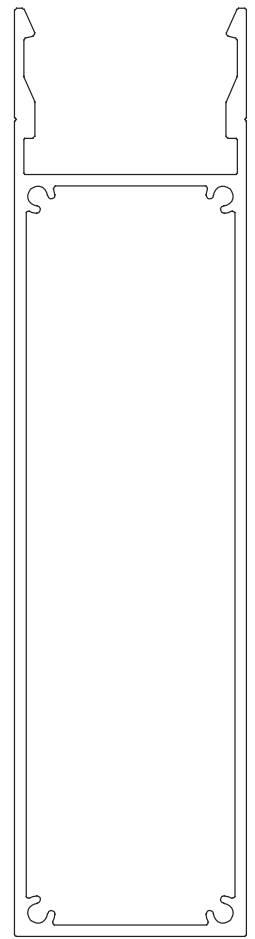

**LVE505**

200 x 50mm Batten



# Batten Configurations

Finished Size	Component Configuration	Sections
50	50 + Flush Infill	LVE501 + LVE502
100	100 + Flush Infill	LVE501 + LVE503
150	150 + Flush Infill	LVE501 + LVE504
200	200 + Flush Infill	LVE501 + LVE505

\*\*Not to Scale\*\*

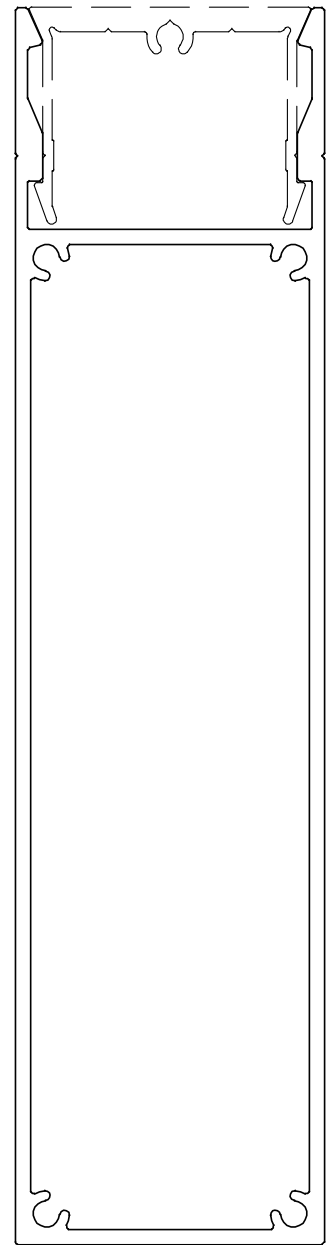
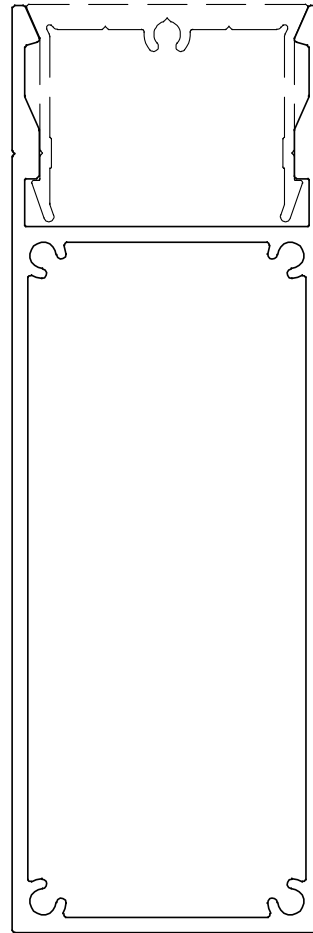
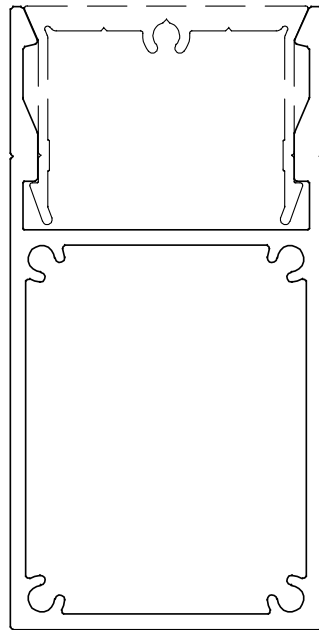
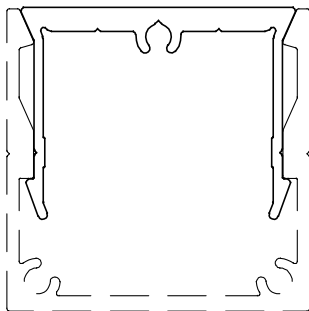
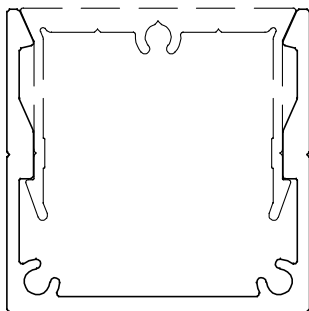

LVE501 + LVE502

LVE501 + LVE503

LVE501 + LVE504

LVE501 + LVE505

## Other Fixed Blade Options

- Self mating options available in 40mm, 50mm and 75mm configurations
- RHS sections with screw flutes



RB4SF

100 x 50 x 3mm RB4 with Screw Flutes

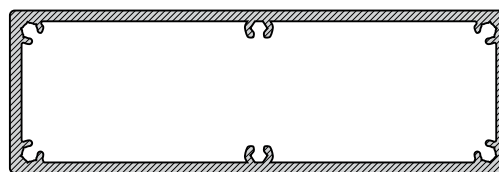

RB6SF

150 x 50 x 3mm RB6 with Screw Flutes

**HEAD OFFICE** | 3 Alspec Place Eastern Creek NSW 2766  
Phone: 02 9834 9500 | Fax: 02 9834 9532 | [info@alspec.com.au](mailto:info@alspec.com.au)

**SYDNEY BRANCH**  
3 Alspec Place  
Eastern Creek NSW 2766  
Phone: 02 9834 9500  
Fax: 02 9834 9555  
[sydney@alspec.com.au](mailto:sydney@alspec.com.au)

**NEWCASTLE BRANCH**  
95 Griffiths Road  
Lambton NSW 2299  
Phone: 02 4952 9111  
Fax: 02 4952 9728  
[newcastle@alspec.com.au](mailto:newcastle@alspec.com.au)

**PERTH BRANCH**  
30 Holder Way  
Malaga WA 6090  
Phone: 08 9209 9100  
Fax: 08 9209 9199  
[perth@alspec.com.au](mailto:perth@alspec.com.au)

**CAIRNS BRANCH**  
11 Southgate Close  
Woree QLD 4868  
Phone: 07 4037 6666  
Fax: 07 4037 6699  
[cairns@alspec.com.au](mailto:cairns@alspec.com.au)

**BRISBANE BRANCH**  
8-22 Jutland Street  
Loganlea QLD 4131  
Phone: 07 3089 4900  
Fax: 07 3089 4999  
[brisbane@alspec.com.au](mailto:brisbane@alspec.com.au)

**ADELAIDE BRANCH**  
1 Pope Court  
Beverley SA 5009  
Phone: 08 8150 6960  
Fax: 08 8150 6999  
[adelaide@alspec.com.au](mailto:adelaide@alspec.com.au)

**TOWNSVILLE BRANCH**  
21 Carroll Street  
Mount Louisa QLD 4814  
Phone: 07 3089 4965  
Fax: 1300 131 747  
[townsville@alspec.com.au](mailto:townsville@alspec.com.au)

**MELBOURNE BRANCH**  
26-40 Pound Road West  
Dandenong South VIC 3175  
Phone: 03 8787 6333  
Fax: 03 8787 6399  
[melbourne@alspec.com.au](mailto:melbourne@alspec.com.au)

**DARWIN BRANCH**  
25 Bishop Street  
Woolner NT 0820  
Phone: 08 8941 7300  
Fax: 08 8941 7322  
[darwin@alspec.com.au](mailto:darwin@alspec.com.au)



Call 1300 ALSPEC  
[alspec.com.au](http://alspec.com.au)