



WOVEN IMAGE®

DESIGN DEPARTMENT - PRODUCT SPECIFICATION SHEET

ISSUE DATE: 20.02.19

| | |
|-------------------|--|
| DESIGN NAME: | Ascent |
| DESIGNER: | Woven Image |
| ORIGIN: | Australia |
| COLOURS: | 5 |
| COMPOSITION: | 100% PET (67% Recycled) |
| TILE DIMENSIONS: | 500mm (+/-5mm) x 900mm (+/-5mm) x 50mm (+/- 5 mm) |
| WEIGHT: | 770grams per tile +/- 10 % |
| THICKNESS: | 4.0mm +/- 0.5mm (measured 10mm above trimmed edge) |
| STD BOX CONTENTS: | 6 Ascent Tiles Mixed bag of clips for a 3 Tile x 2 Tile configuration Installation guide |

PERFORMANCE

| | |
|---------------------------|--|
| COLOUR FASTNESS TO LIGHT: | ISO 105 B02 Rating: 6 |
| FIRE TEST: | AS3837 Classification Group 3 |
| SOUND ABSORPTION | AS ISO 354 – 2006 NRC Value: 0.70 (tile only) 0.90 (tile + optional baffle infill) |
| VOC EMISSIONS: | ASTM D5116 - 0.008 mg/m2/hr (7 days) |

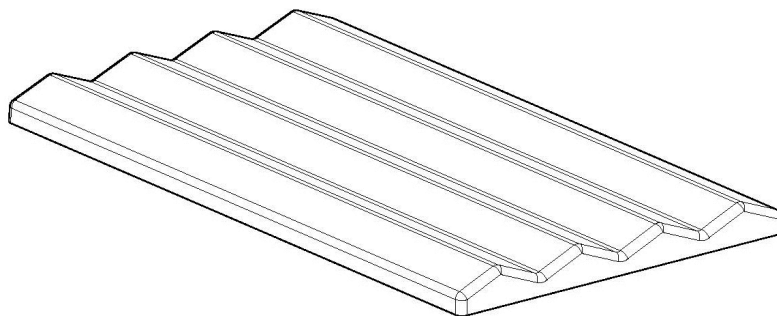

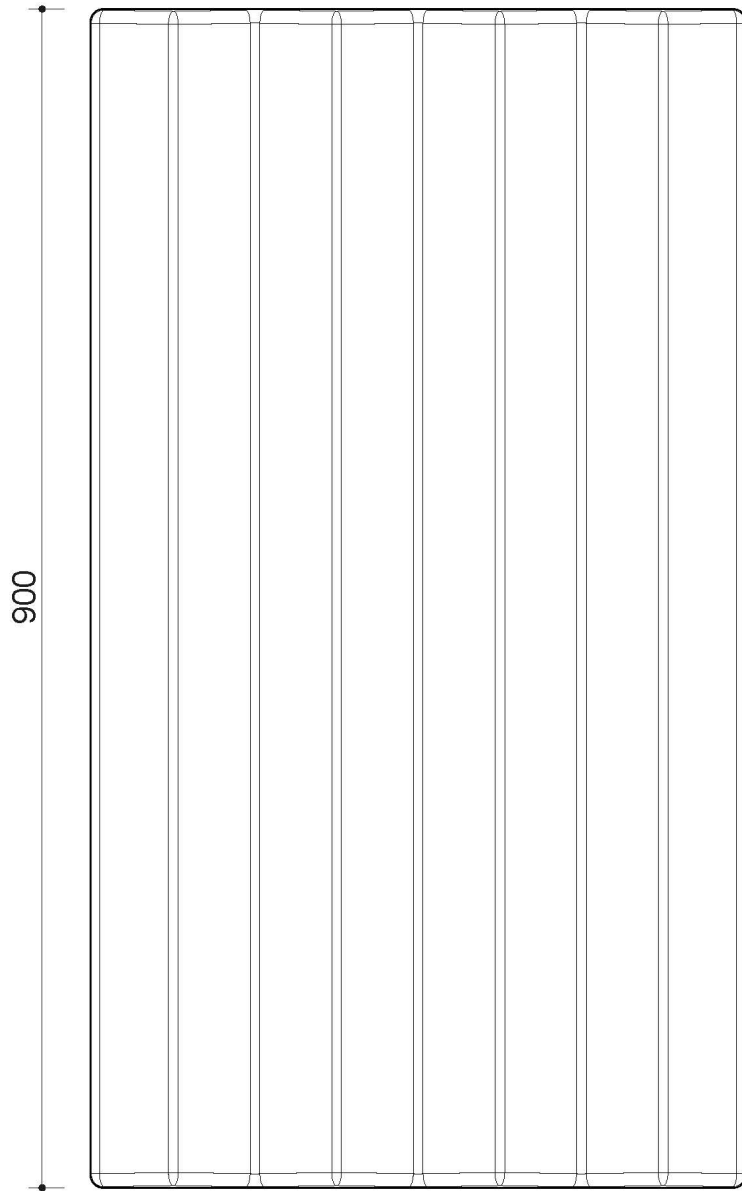
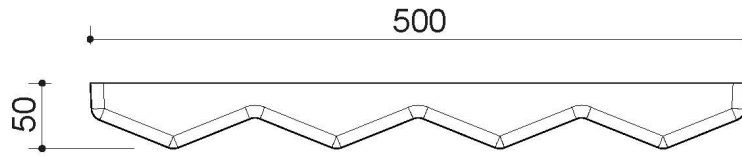

DISCLAIMER: Ascent Tiles may have a variation in colour on the edge of the tile and corner creases due to the production process, present stock colour may vary from sample.

For more information phone +61 2 9913 8668 or 1800 888 650 or visit www.wovenimage.com