

Insulation



# Kooltherm®

## K10 PLUS Soffit Board

Insulated Fibre Cement Sheet for Concrete Soffits



- Rigid thermoset phenolic insulation
- Non-combustible building board outer face
- Fibre-free, closed cell insulation core
- Group 1 NCC fire classification
- Resistant to the passage of water vapour
- NCC and AS/NZS 4859.1:2018 compliant
- Made in Australia



# Typical Constructions and Total R-values

## Concrete Soffit Floor / Roof Installation

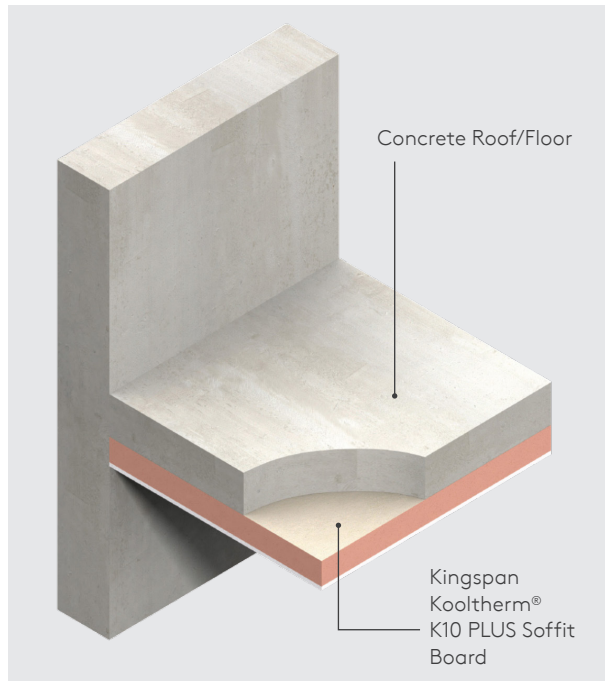

Figure 1. Concrete soffit floor/roof installation.

## Thermal Performance

**Total R-values for various thicknesses of Kingspan Kooltherm® K10 PLUS Soffit Board**  
 Applicable for NCC Volume One, Class 2 to 9 buildings & NCC Volume Two, Class 1 & 10a buildings.

Roof application, no ceiling (150 mm concrete)		
Product Thickness*	Heat Flow In	Heat Flow Out
31 mm	R <sub>T</sub> 1.4	R <sub>T</sub> 1.4
36 mm	R <sub>T</sub> 1.6	R <sub>T</sub> 1.6
46 mm	R <sub>T</sub> 2.0	R <sub>T</sub> 2.1
56 mm	R <sub>T</sub> 2.5	R <sub>T</sub> 2.6
66 mm	R <sub>T</sub> 3.0	R <sub>T</sub> 3.1
76 mm	R <sub>T</sub> 3.4	R <sub>T</sub> 3.5
86 mm	R <sub>T</sub> 3.8	R <sub>T</sub> 4.0
96 mm	R <sub>T</sub> 4.3	R <sub>T</sub> 4.5

\* Product thickness = nominal insulation thickness + 6 mm Fibre Cement sheet

**Total R-values for various thicknesses of Kingspan Kooltherm® K10 PLUS Soffit Board**  
 Applicable for NCC Volume One, Class 2 to 9 buildings & NCC Volume Two, Class 1 & 10a buildings.

Unenclosed sub-floor application (150 mm concrete)		
Product Thickness*	Heat Flow In	Heat Flow Out
31 mm	R <sub>T</sub> 1.3	R <sub>T</sub> 1.4
36 mm	R <sub>T</sub> 1.5	R <sub>T</sub> 1.7
46 mm	R <sub>T</sub> 2.0	R <sub>T</sub> 2.1
56 mm	R <sub>T</sub> 2.5	R <sub>T</sub> 2.7
66 mm	R <sub>T</sub> 2.9	R <sub>T</sub> 3.1
76 mm	R <sub>T</sub> 3.3	R <sub>T</sub> 3.6
86 mm	R <sub>T</sub> 3.8	R <sub>T</sub> 4.0
96 mm	R <sub>T</sub> 4.2	R <sub>T</sub> 4.5

\* Product thickness = nominal insulation thickness + 6 mm Fibre Cement sheet

### Assumptions

The R-values shown are Total R-values for the building element as required by the Energy Provisions of the National Construction Code 2022, calculated in accordance with AS/NZS 4859.2:2018 & NZS 4214:2006. Kingspan Kooltherm® products are manufactured, tested and packaged in conformance with AS/NZS 4859.1:2018

# Product Details

## Product Description

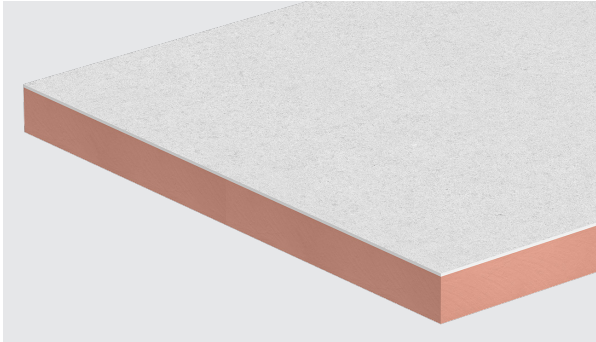

Figure 2. Kingspan Kooltherm® K10 PLUS Soffit Board.

Kingspan Kooltherm® K10 PLUS Soffit Board is a fibre-free rigid thermoset, closed cell phenolic insulation core, sandwiched between a front facing fibre cement sheet and a reverse tissue based facing autohesively bonded to the insulation core during manufacture.

### Product Data

Declared Thermal Conductivity ( $\lambda$ -value) AS/NZS 4859.1:2018 / ASTM C518-2017	Insulant	0.022 W/m.K at 23°C
		Insulant thickness $\geq$ 45 mm
	Fibre Cement	0.023 W/m.K at 23°C
		Insulant thickness 25-44 mm
		0.23 W/m.K at 23°C
		Fibre Cement thickness 6 mm
Product Dimensions	2400 mm x 1200 mm (2.88 m <sup>2</sup> ) Other dimensions available upon enquiry. Minimum order quantities apply.	
Nominal Product Thickness (inc. Fibre Cement Sheet)	31, 36, 46, 56, 66, 76, 86 and 96 mm	
Nominal Fibre Cement Sheet Thickness	6 mm	

A selection of alternative lining boards to create customised finishes and facings is available. Please contact us for more information.

## Product R-value

Nominal Product Thickness	Declared Product R-value at 23°C
31 mm	R1.10
36 mm	R1.40
46 mm	R1.75
56 mm	R2.30
66 mm	R2.75
76 mm	R3.25
86 mm	R3.70
96 mm	R4.15

## Specification Guide

### Kingspan Kooltherm® K10 PLUS Soffit Board

The soffit insulation shall be Kingspan Kooltherm® K10 PLUS Soffit Board \_\_\_ mm thick, with a tested smoke obscuration of not more than 100 m<sup>2</sup>/kg, comprising a rigid thermoset phenolic insulation core with a front facing non-combustible fibre cement sheet and a reverse tissue based facing, manufactured under a management system certified to ISO 9001:2015, ISO 14001:2015, ISO 45001:2018 and ISO 50001:2018 by Kingspan Insulation Pty Ltd and shall be installed in accordance with the instructions issued by them.

A Project Specific Warranty provided by Kingspan Insulation must be submitted.

# Product Details

## Standards and Approvals

Kingspan Kooltherm® K10 PLUS Soffit Board is manufactured to the highest standards and certified under the following management systems:

Standard	Management System
ISO 9001:2015	Quality Management
ISO 14001:2015	Environmental Management
ISO 45001:2018	Occupational Health and Safety
ISO 50001:2018	Energy Management

## Product Testing

Characteristic	Standard	Result
Compressive Stress (Insulant)	AS 2498.3:1993	On average exceeds 100 kPa at 10% compression
Water Vapour Transmission	ASTM E96 Part B-2016	> 35 MN-s/g For the purpose of calculation of condensation risk, the resistivity of the fibre cement sheet component of the product should be taken as 250 MN-s/g-m.

## Fire Performance

Test	Test Method	Result
Early Fire Hazard Properties. (Ignitability, Flame spread, Heat release, Smoke release)	AS 1530.3:1999	Spread of Flame Index: 0 Smoke Development $\leq 3^*$
NCC Group Number	AS 5637.1:2015 / AS ISO 9705:2003 (R2016)	Group 1
Average Specific Extinction Area	AS/NZS 3837:1998	$\leq 100 \text{ m}^2/\text{kg}^{**}$

\* Applies only to the Kingspan Kooltherm® K10 insulation board used in the manufacture of this composite insulated fibre cement product.

\*\* Applies to compliant fibre cement facing.

## Durability

If correctly applied, Kingspan Kooltherm® products can be expected to have a long life of service.

Their durability depends on the supporting structure and the conditions of its use.

Kingspan Kooltherm® products are warranted for a period of 10 years for both residential and commercial installations.\*

\* Subject to the terms of the complete Kingspan Kooltherm® warranty document which is available upon request or downloadable from [www.kingspaninsulation.com.au](http://www.kingspaninsulation.com.au)

## Environmental Data

Aspect	Characteristic
Re-usability	Re-usable if removed with care (long term of service expected)
Water Use	No water used in Kingspan Insulation's manufacturing process

# Installation Instructions

## Fibre Cement Sheet

Kingspan Kooltherm® K10 PLUS Soffit Board must be installed in accordance with AS 2908.2:2000 Cellulose Cement Products.

Installation must be in accordance with AS 3999:2015 Bulk Thermal Insulation Installation and AS 3000:2018 Electrical Installations (Wiring Rules).

## Fixing Directly to Concrete Soffits

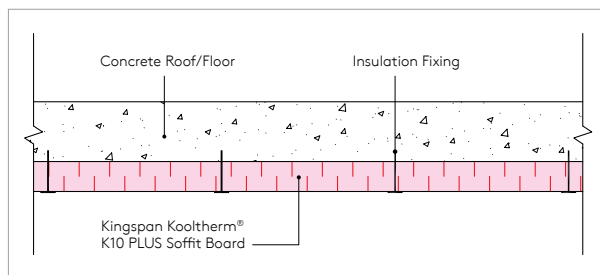

Figure 3. Side elevation - Concrete Soffit with Kingspan Kooltherm® K10 PLUS Soffit Board.

Kingspan Kooltherm® K10 PLUS Soffit Board can be fully restrained to a concrete soffit by the use of minimum eleven appropriate insulation fasteners with a minimum head diameter of 25 mm.

1. The fasteners should be evenly distributed over the whole area of the board and designed to provide suitable restraint for the project requirements. Consultation with the chosen fastener supplier is recommended.
2. Board joints can be either staggered (see Figure 5) or squared (see Figure 6). Four fasteners along each length - no less than 50 mm - no more than 150 mm from edge of board, three fasteners along the middle (offset from edge positions as per diagram Figure 4).
3. Where the board may be subject to external wind pressure, the requirement for additional fixings should be assessed in accordance with appropriate Australian wind load standards.
4. Consideration should be given to the material the fixing is made from and should be deemed appropriate for application, exposure and fire rating by the fixing manufacturer.

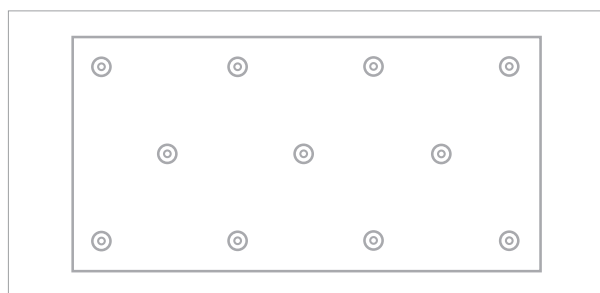

Figure 4. Fastener pattern (11 per board).  
Board size to 2400 mm x 1200 mm - 3.81 fixings / m<sup>2</sup>

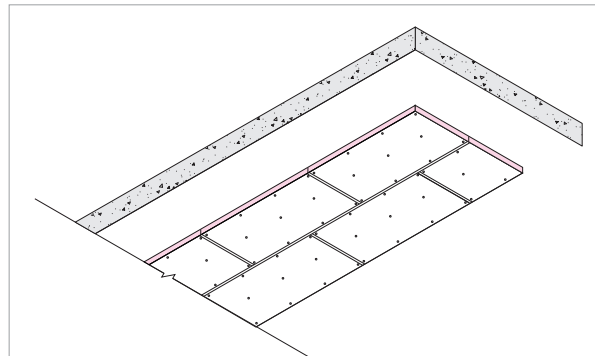

Figure 5. Board joints staggered.

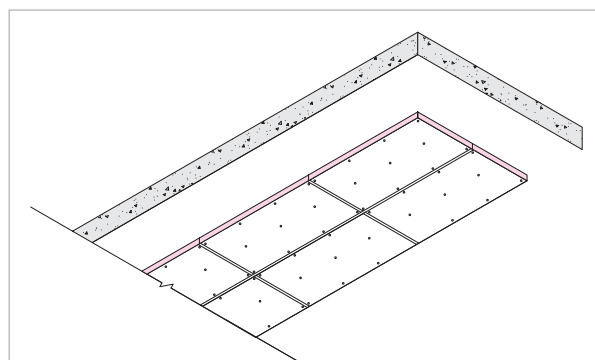

Figure 6. Board joints squared.

## Why 11 fixings?

Best practice determines that any rigid board insulation, not just Kingspan Kooltherm® K10 PLUS Soffit Board, should be fixed with 11 mechanical fixings for very good reasons:

- There will always be differential expansion and contraction between any rigid insulation material and adjacent building elements due to varying moisture content and temperature.
- Excessive movement occurring between boards, can place undue stress on the foil tape at the joint and result in peeling.
- In any concrete forming, there will be an uneven surface throughout the slab.
- Where concrete formwork is joined it is normal to have ridges of up to 3 mm which makes the concrete surface uneven.
- An insulation board held horizontally may bow in time like any other sheet material under its own weight, which can look unsightly and cause tape to peel off.
- Some direct fastener solutions can have a high failure rate, which may not be apparent to the installer at first.
- It provides a proven robust fire safe solution. It limits the ability for the fibre cement facer to peel off in a fire event and obstruct fire sprinklers. It also reduces the potential for falling debris, i.e. chunks of insulation falling, causing a hazard for firefighters entering the building and occupants exiting the building.

---

# Installation Instructions

---

Using 11 fixings ensures that the insulation board has a strong and permanent fix under the concrete soffit and that it is not compromised by any of the above issues.

These best practice recommendations are a result of over 30 years of Kingspan Insulation experience in soffit applications.

Companies promoting less fixings, as low as 6 or 7, in the market have not been in the market for long and have not yet expired their warranty periods.

## Fixing to Timber Battens / Furring Channels

1. Alternatively, a treated softwood batten/furring channel lay-out may be adopted if there is an uneven surface or mechanical services present and direct fixing is not possible.
2. 50 mm x 25 mm battens/furring channels should be placed at 600 mm centres to coincide with the edges/centres of the boards.
3. The battens/furring channels should be fixed to the soffit by the use of a suitable fixing method e.g. shot-fire may be considered.
4. Kingspan Kooltherm® K10 PLUS Soffit Board should then be fixed to the treated timber battens/furring channels using suitable screw fixings. These should be placed at maximum 300 mm in rows not greater than 600 mm apart.
5. Locate fasteners not less than 12 mm from sheet edges and 50 mm from sheet corners.
6. Where the board may be subject to external wind pressure, the requirement for additional fixings may need to be assessed in accordance with appropriate wind load standards.

For advice on ancillary materials, such as fixings and tapes please contact our Technical Services Department.

## Installation around Fire Collars

1. Fitting Kingspan Kooltherm® K10 PLUS Soffit Board tight to the fire collar is recommended to reduce the effects of thermal bridging through the slab.
2. Do not cover the exposed face of embedded cast in fire collars.



Figure 7. Penetration example - Kingspan Kooltherm® K10 G2 Soffit Board installed tight around the fire collar and HDPE service pipe.



Scan to see installation video  
“Fixing Directly to Concrete Soffits”

---

# Other Information

---

## General

### Cutting

Cutting fibre cement sheets should be carried out by using a suitable fibre cement blade. For alternative lining materials ensure an appropriate blade is used. Ensure accurate trimming to achieve close-butting joints and continuity of insulation.

### Taping

Taping is not required for bonded boards. In the absence of other protection, exposed board edges should be protected by silver Kingspan Insulation Tape with a minimum 48 mm wide overlap onto the board face (see Figure 8) or alternatively use a proprietary metal c-section.

However, to reduce vapour transmission consideration should be given to sealing the joints.

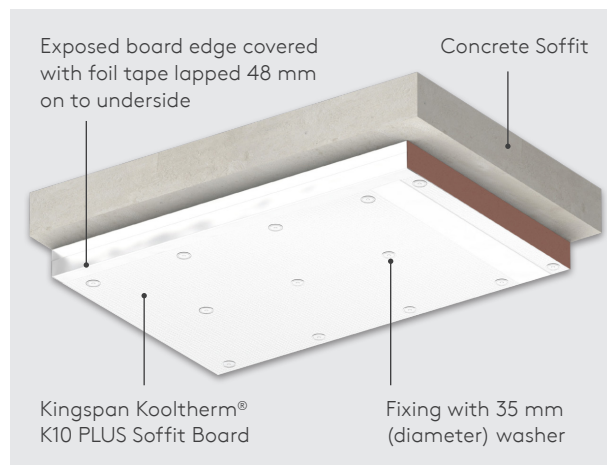

Figure 8. Protection of exposed insulation edges of Kingspan Kooltherm® K10 PLUS Soffit Board

### Packaging

According to quantity, the boards are supplied in packs, labelled and shrink-wrapped in polythene.

## Handling and Storage

### Storage

The packaging of Kingspan Kooltherm® should not be considered adequate for long term outdoor protection. Ideally boards should be stored inside a building. If, however, outdoor storage cannot be avoided then the boards should be stacked clear of the ground and covered with an opaque polythene sheet or weatherproof tarpaulin. Boards that have been allowed to get wet should not be used.

### Resistance to Solvents

The insulation core is resistant to short-term contact with petrol and with most dilute acids, alkalis and mineral oils. However, it is recommended that any spills be cleaned off fully before the boards are installed. Ensure that safe methods of cleaning are used, as recommended by suppliers of the spilt liquid. The insulation core is not resistant to some solvent-based adhesive systems, particularly those containing methyl ethyl ketone. Adhesives containing such solvents should not be used in association with this product. Damaged boards or boards that have been in contact with harsh solvents or acids should not be used.

### Safety Information

Kingspan Insulation products are chemically inert and safe to use. A Product Safety Information sheet is available from Kingspan Insulation Pty Ltd.

---

# Contact Details

---

## Australia

Kingspan Insulation Pty Ltd  
T: 1300 247 235  
E: [info@kingspaninsulation.com.au](mailto:info@kingspaninsulation.com.au)  
[www.kingspaninsulation.com.au](http://www.kingspaninsulation.com.au)



---

© Kingspan, Kooltherm and the Lion Device are Registered Trademarks of the Kingspan Group plc in Australia and other countries. All rights reserved. © Kingspan Insulation Pty Ltd.

Kingspan Insulation Pty Ltd reserves the right to amend product specifications without prior notice. The information, technical details and fixing instructions etc. included in this literature are given in good faith and apply to uses described. Recommendations for use should be verified as to the suitability and compliance with actual requirements, specifications and any applicable laws and regulations. For other applications or conditions of use, Kingspan Insulation offers a Technical Advisory Service the advice of which should be sought for uses of Kingspan Insulation products that are not specifically described herein. Please check that your copy of the literature is current by contacting us or visiting <https://www.kingspan.com/au/en/products/insulation/roof-insulation/kooltherm-k10-plus-soffit-board/>

