

The mechanical turnstile is the ideal solution for controlling Customer flow on a limited budget.

This turnstile is compact yet very effective -allowing throughput to be controlled with only minimum supervision. It is a proven design and is constructed from the highest quality materials to give total reliability. The added benefit to this particular unit is that the turnstile has a built in safety feature. When the turnstile is lifted up, the whole unit can be moved to give a clear wide exit in emergencies.

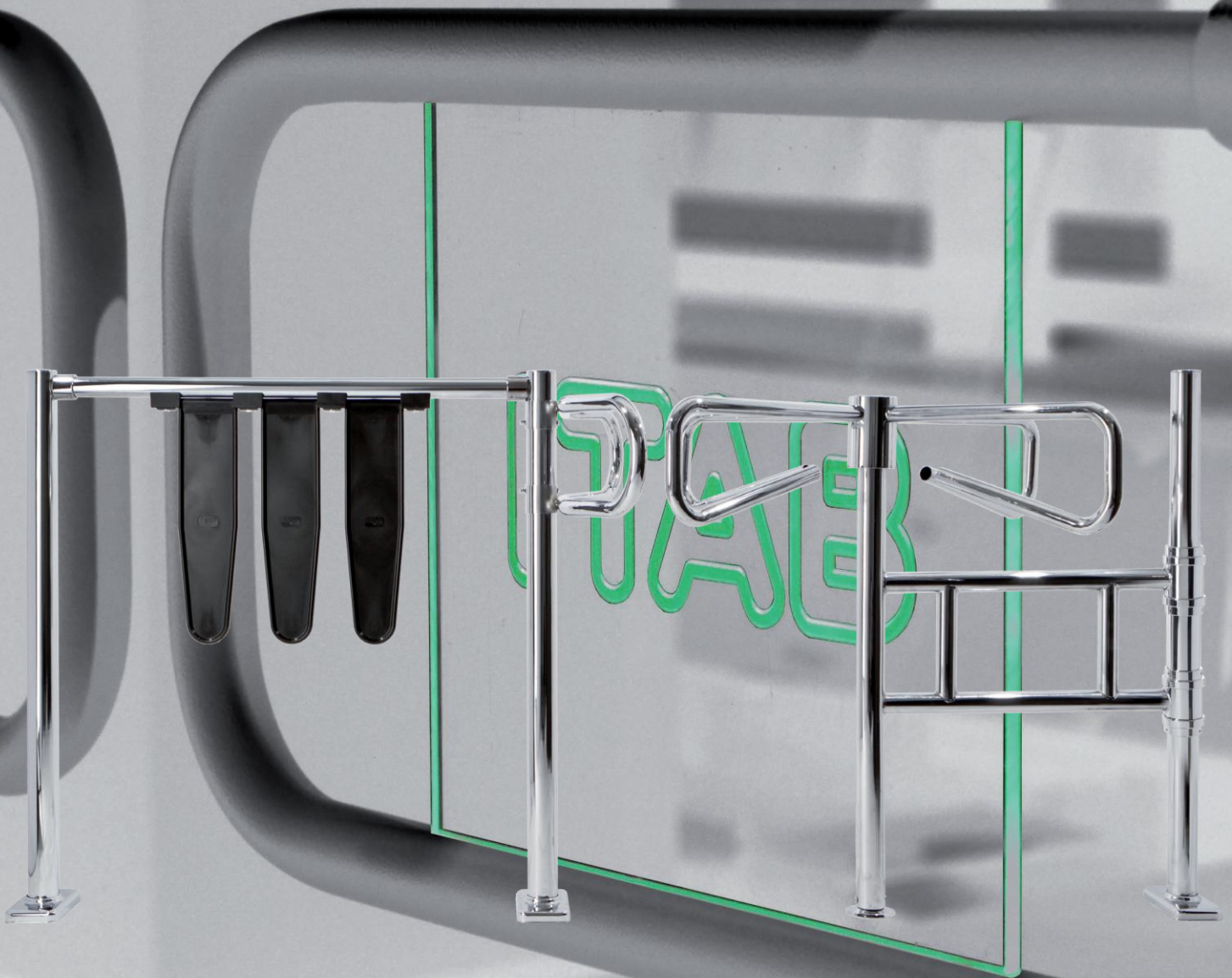

Mechanical Turnstile



Design

- Turnstile is available with or without trolley flaps.
- Turnstile has an emergency exit breakout facility as standard.
- Turnstile is available in either a clockwise or anti-clockwise configuration.
- Chrome plated finish as standard.
- Can be used in conjunction with our standard barrier rail range, to provide a controlled store entrance/exit.
- Minimum 1350mm width required (without trolley flap).
- Trolley flaps rail available in 500mm (3 flaps), 1000mm (4 flaps) or 1500mm (5 flaps) as standard with Red, Black or Grey flaps.

Trolley Flaps



Black



Grey



Red

TECHNICAL DETAILS

Opening Controls	Manual
Break-out Facility	Lift up Emergency break-out facility with manual reset
Functionality	Left or Right 360 Degree operation



Dimensions

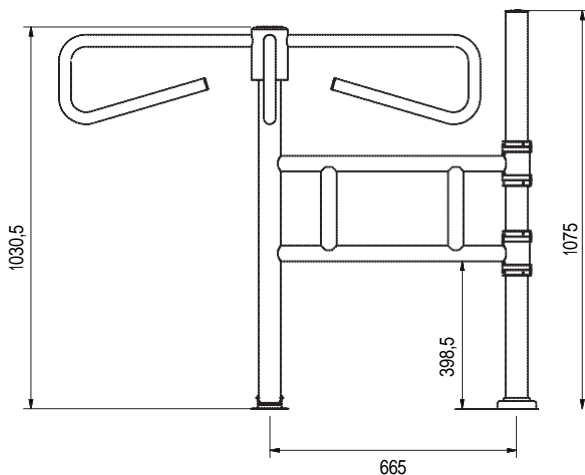

Foot print

