



The Pulse Junior Tri-Fountain drinking fountain and bottle refill station is a robust, economical solution designed especially for junior primary school campuses in areas of high usage.

The station features three drinking fountains and two anti-bacterial bottle refill dispensing nozzles at a reduced height suitable for young children. Customisable, vandal-resistant signage panels allow for educational artwork to be presented on the exterior, making the station an attractive element in the school landscape.

Product features

- 1200mm height
- Two anti-bacterial bottle refill points
- Three stainless steel drinking fountains, fitted with soft drinking mouth guards
- Customisable graphic panels with anti-graffiti protection
- Removable panel for easy filter replacement
- Two year warranty*

Additional options

- Optional inbuilt water filter
- Optional remote water chiller
- Optional inbuilt water meter
- Optional extra deep drinking fountain basin (DDA Compliant wheelchair accessible)

Technical Details

Housing frame	Stainless steel
Housing unit	Anodised aluminium
Graphic panels	Stainless steel
Filter unit option	Sub-micron or 5 micron
Filter unit working pressure	10-125 psi (0.7-8.5 bar), non-shock
Water supply connection	1/2 inch supply line with 1/2 inch Male BSP connection
Drainage	40mm PVC

*Please refer to the Aquafil® Product Warranty for full terms and conditions

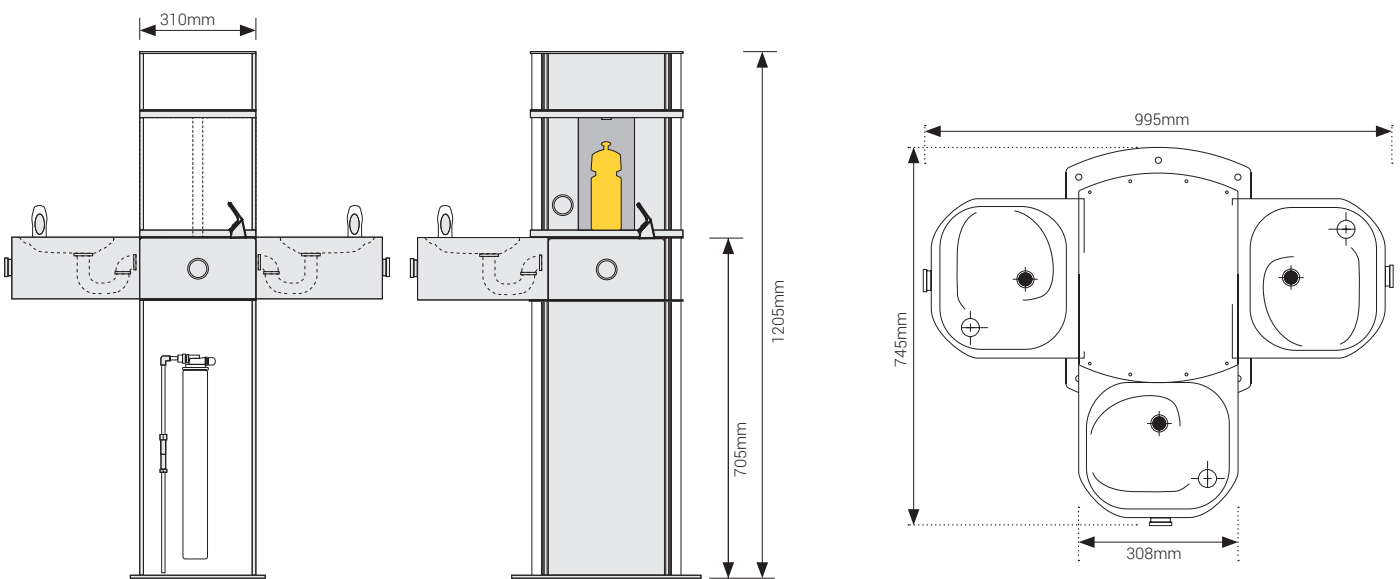
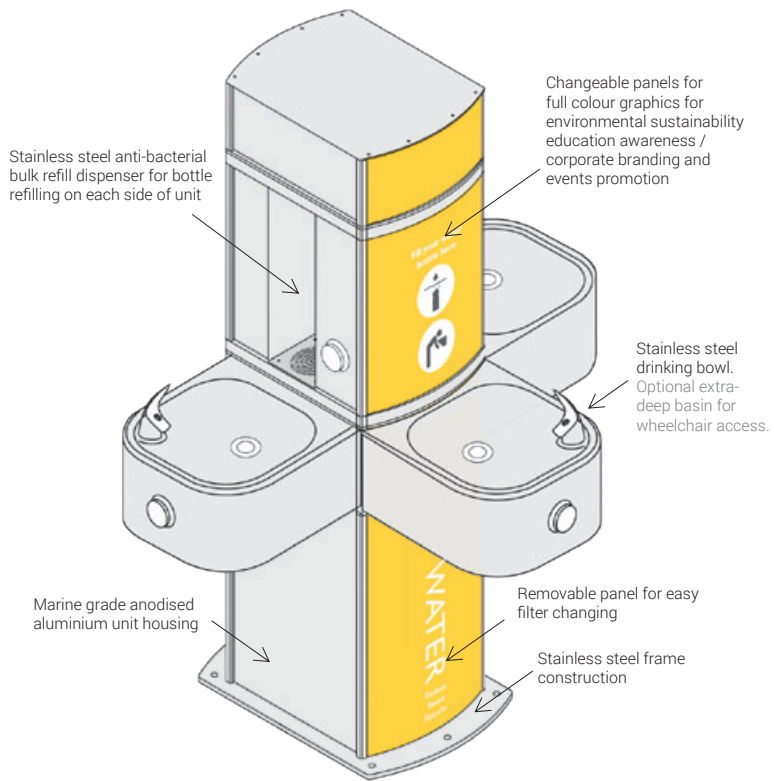

Front & Side view with filter detail

Plan view