



EZCONCEPT

Architectural Finishing Systems



Openings & Finishings

A Studco Innovation





FLUSH FINISH DOOR JAMB SYSTEM

Producing a contemporary flush finish door jamb with clean lines and inconspicuous detail has never been easier for architects, interior designers and developers.

Creating a smooth transition from wall to door; EzyJamb® is a split-type jamb manufactured from cold rolled steel with a patented profile to produce a strong and secure assembly.

Developed with perforated sides for flush jointing, EzyJamb® gives doorways a clean line and modern appearance.

The system is complemented by a range of hardware to suit different applications.

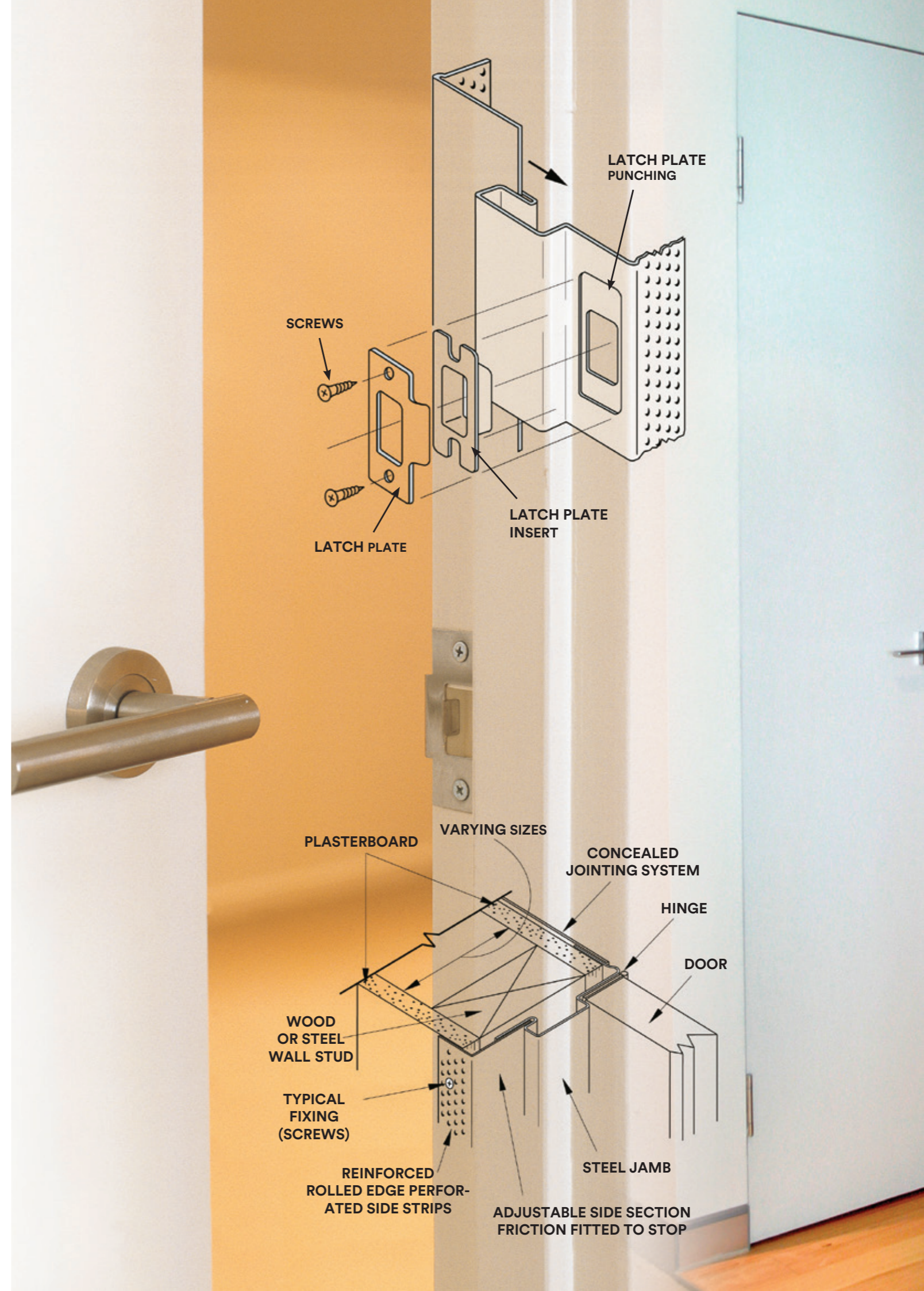

The EzyJamb Range

EZYJamb Classic – EZC

The EZYJamb® Classic Adjust EZC, comes with perforated sides for flush finishing which produces a contemporary flush finish door jamb with clean lines and inconspicuous detail.



EZYJamb Single Rebate – SRC

The EZYJamb® Single Rebate SRC Trimless door frame is simple to install, and it requires no special maintenance.



EZYJamb Inswing – ISD

The EZYJamb® Inswing ISD is suitable in applications where you require the door to open inwardly. The unique design of EZYJamb® combines visual appeal, strength and versatility.



Coming Soon



Homes

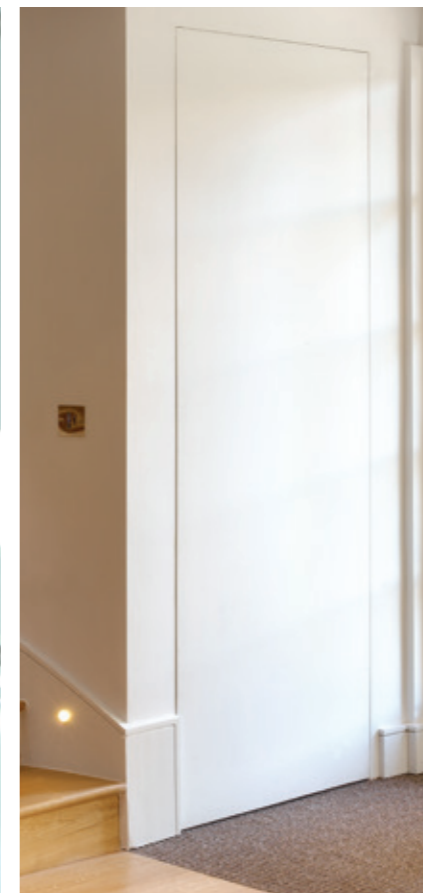

EZYJamb®...The choice for developers over the world... Giving the doorway to your world a sense of a stark, clean environment.



Photo courtesy of Central Equity



Units



Apartments

Full height doors, cavity sliders for small footprint requirements allowing for a sense of uncluttered freedom with the clean line flush finish look.

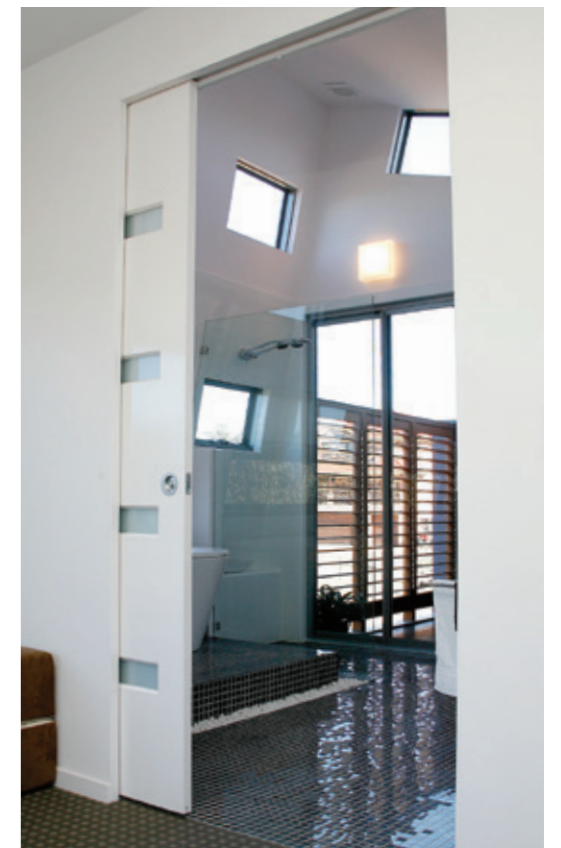

Penthouses

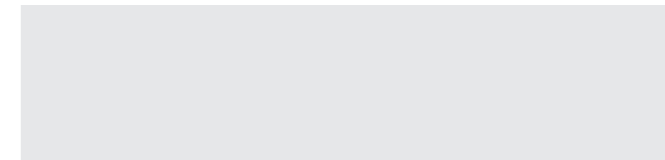
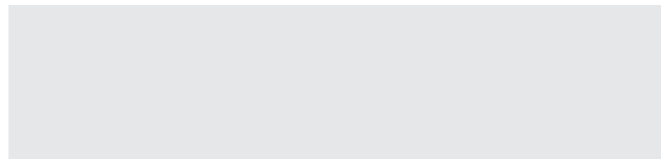
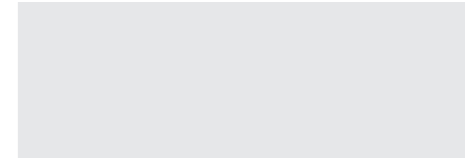
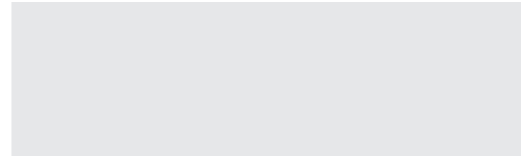
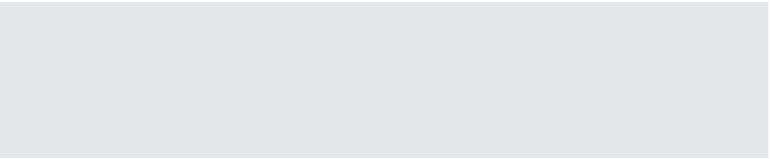

Photo courtesy of Central Equity



The unique design of the EZYJamb® System combines visual appeal, strength and versatility for a commercial environment.

Offices



Showrooms

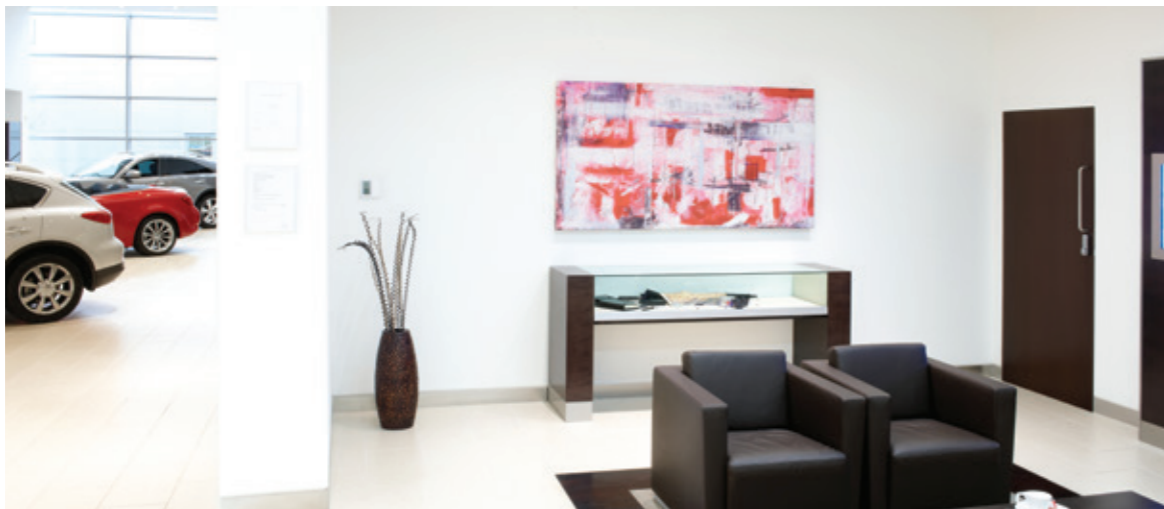

Healthcare

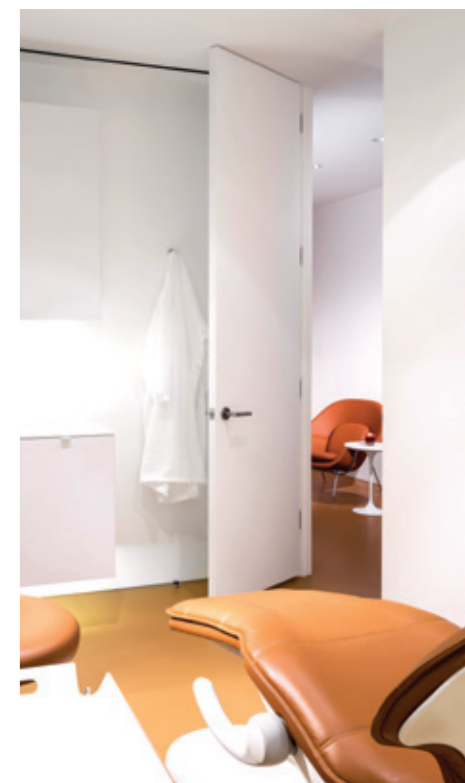

EZYJamb® Flush Finish Cavity Sliding System for premium architectural interiors

The EZYJamb® Flush Finish Cavity Sliding System is a specially designed, premium cavity sliding pocket that offers a totally square set finish around the perimeter of the frame giving you a seamless EZYJamb® look right throughout your project.

The unique design gives an absolute minimum of detail, allowing the door to be completely concealed and give the impression that the door does not exist when open. When the door is closed, complete privacy is ensured by using a subtle rebate feature. The EZYJamb® Flush Finish Cavity Sliding System uses a 'zero clearance' head track that eliminates the needs for removable pelmets at the top of the door.

EZYJamb® Flush Finish Cavity Sliding System is available in standard sizes that are suitable for any architectural interior including high rise apartments, domestic housing and modern offices. Custom sizes may be available upon request.

Door Height mm	Door Width mm
2040	720
	820
	920
2340	720
	820
	920



The Flush Finish Cavity Slider Kit for any sliding door

The EZYJamb® Cavkit is used to transform most standard cavity sliding units into architrave free, flush finish doors. A combination of special finishing sections made from premium quality steel encase the door opening to provide a durable, clean line finish that is consistent with other products from the EZYJamb® range.

The dimensions of the EZYJamb® Cavkit sections are designed to comfortably fit on a variety of common cavity sliding door systems from budget pocket doors to premium architectural sliders. Please refer to separate EZYJamb Cavkit datasheet and confirm exact fit prior to ordering.

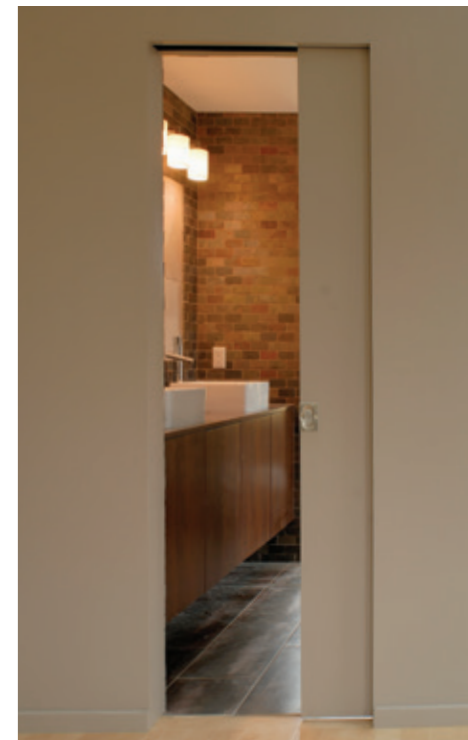
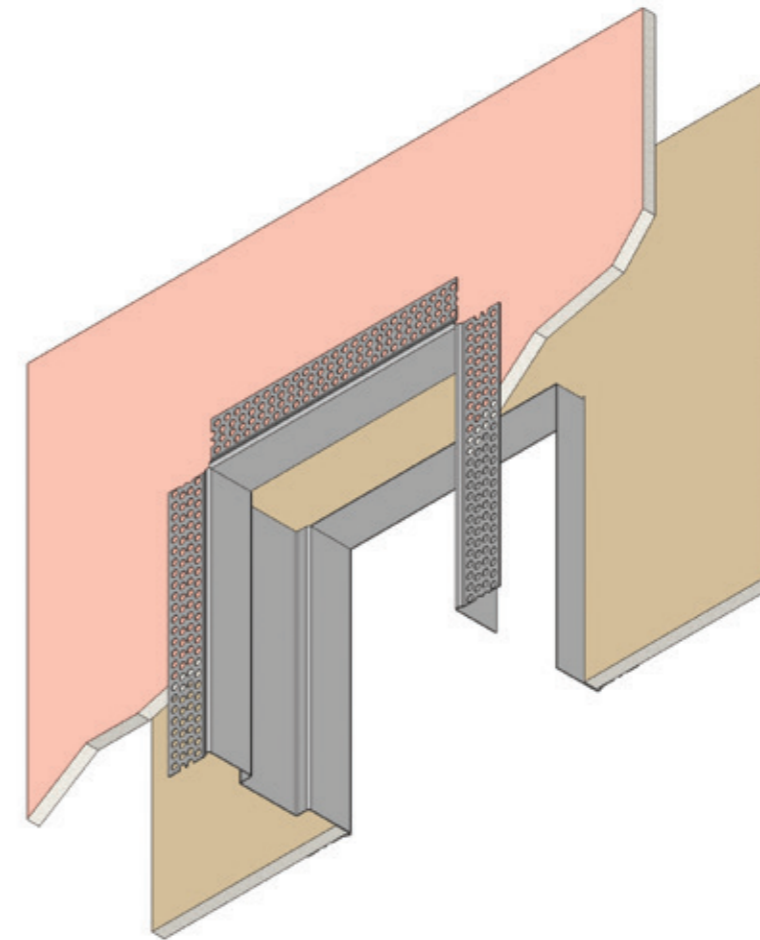

EzyReveal

- Designed for quick and economical finishing of reveal from 20 to 250mm.
- Manufactured from cold rolled steel providing a strong and secure reveal eliminating warping, twisting, cracking and damage from UV Rays.
- Enquire for custom size reveal lengths (width)

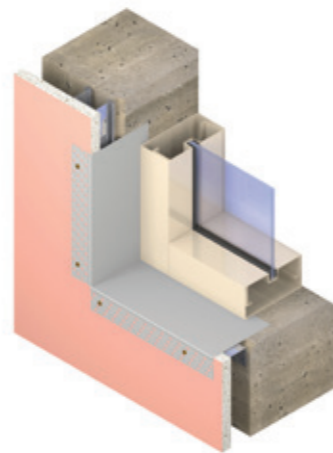
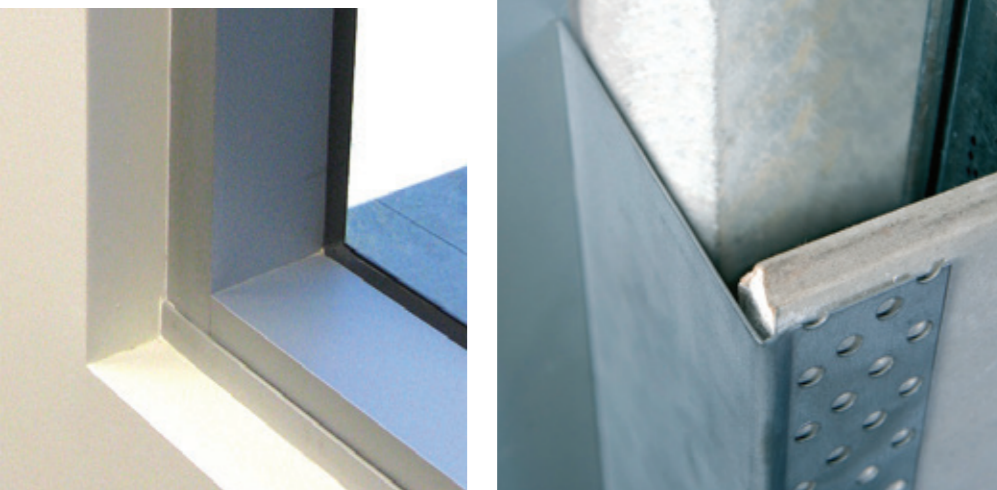

Quick and economical finishing of reveals

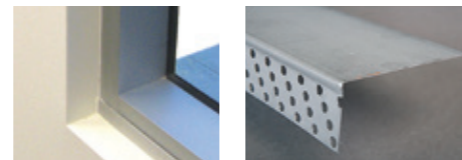

AluBase Aluminium Skirting

- Contemporary, robust skirting for simple modern clean line appearance.
- Excellent resilience to wear, with good impact resistance
- Retains strength and requires minimal maintenance

Code	Dimensions	Description
SLS1090-36	3600	Shadowline Skirting 10mm N/A 89mm x 3600
SLS1390-36	3600	Shadowline Skirting 13mm N/A 89mm x 3600
SLSCNR		Corner Joiner (Pair)
SLSJOI		Staright Joiner (Pair)
SKA78		Skirting Adhesive 300ml Cartridge

Code	Dimensions	Description
SK100-36	3600	Alum Skirting N/A 100mm x 1.6 x 3600
SK100BL-36	3600	Alum Skirting N/A with Insert x 3600
SK100S	1000	Corner Stake to Suit Alum Skirting
SK80-36	3600	Alum Skirting N/A 80mm x 1.6 x 3600
SKINS-BLK	3600	Alum Skirting Insert Black Roll per m
SKINS-GRY	3600	Alum Skirting Insert Grey Roll per m

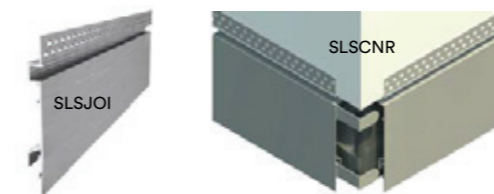

EzyCap The strong and versatile alternative for stop ends



- Designed for quick and economical finishing of wall ends.
- Manufactured from cold rolled steel providing a strong and secure wall and end cap that is both durable and fast to install.
- Hard to reach wall ends made possible with Ezycap®.
- Available in a range of sizes to suit various wall configurations.



FastCap

Rebates....Fastcap is the answer.
Custom finishing and capping of plasterboard is made easy with the Fastcap range of custom finishing sections.

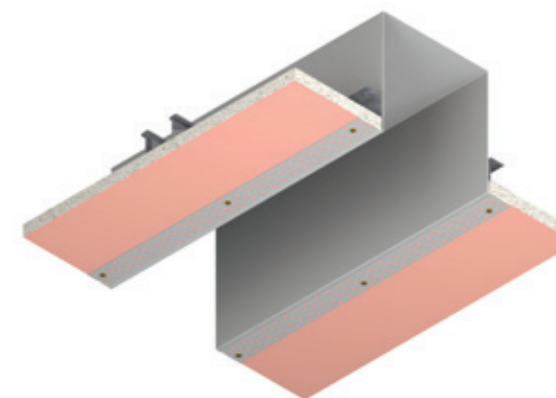

Custom finishing and capping of plasterboard is made easy with Fastcaps® range of custom made finishing sections. Our custom design and consultancy team is ready to help design and produce an innovative solution to your requirements for any size project. Fastcaps® custom finishing sections make the finishing of difficult plasterboard profiles, rebates and large oversized shadowlines a dream.

- Light troffers
- Recessed curtain pelmets
- Ceiling features
- Sliding door receptacle
- Flush-finish bookshelves
- Recessed wall features

Enquire now for a fast solution to all your requirements.





Make your door hinges disappear with the all new RocYork® concealed door hinge from EZYJamb! This revolutionary architectural breakthrough will allow uninterrupted clean lines around internal doors for the ultimate square-set interior.

Check out some of the features and benefits of the RocYork® concealed door hinge from EZYJamb®...

- No visible barrel or pin
- Maintenance free bearing mechanism
- Aesthetically pleasing hinge covers

RY-45

3 axis adjustable hinge 5 fulcrums

Finishing	Satin chrome
For Panels	920mm x 2340mm
Door thicknesses	35mm, 38mm, 45mm
Adjustments	X: Horizontal +3,-2 Y: Depth ±1 Z: Vertical ±2.5
Capacity	45 kgs (2) RY-45 hinges 60 kgs (3) RY-45 hinges
Cover	Satin chrome



Tested to UL 10C Standards



Hinge barrels disappear from view with RocYork's concealed hinges, leaving subtle clean lines around the EZYJamb®.

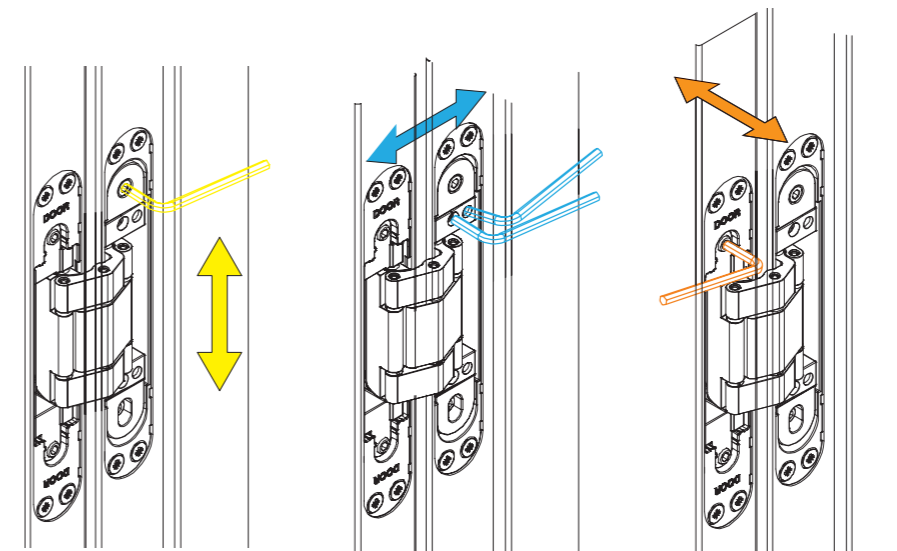

3 Axis of Adjustment - The hinge can be adjusted in three directions to align door margins

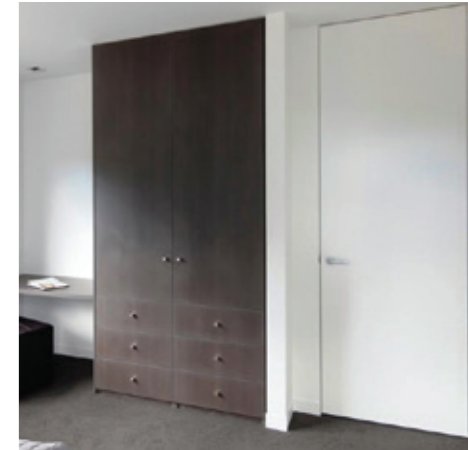

Hinges Only

Code	Description	Pack
RY45	45kg rating for 2 hinges	5

*Non stock item.
Lead time applies.



Hirline Hinge

EZYJamb® stainless steel loose pin hirline hinges are offered with the EZYJamb® system. These hinges are surface mounted making for easy installation.

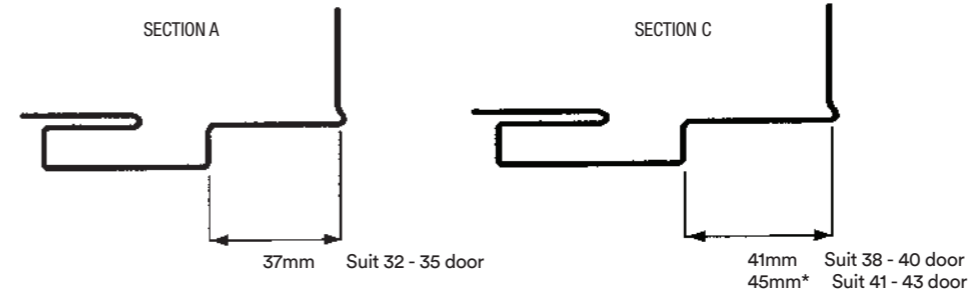
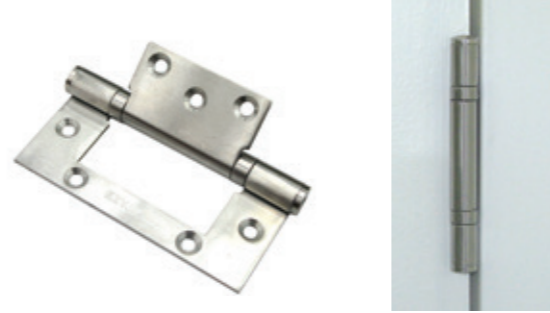

SECTION A TOLERANCES COMBINATIONS	FINISHED WALL	
	MINIMUM	MAXIMUM
SECTION A & RA25	82mm	91mm
SECTION A & RA35	91mm	101mm
SECTION A & RA45	101mm	111mm
SECTION A & RA50	106mm	116mm
SECTION A & RA60	116mm	126mm
SECTION A & RA65	121mm	131mm
SECTION A & RA75	131mm	141mm
SECTION A & RA80	136mm	146mm
SECTION A & RA90	146mm	156mm
SECTION A & RA100	156mm	166mm
SECTION A & RA110	166mm	176mm
SECTION A & RA120	176mm	186mm
SECTION A & RA135	191mm	201mm
SECTION A & RA150	206mm	216mm

SECTION C TOLERANCES COMBINATIONS	FINISHED WALL	
	MINIMUM	MAXIMUM
SECTION C & RA25	85mm	95mm
SECTION C & RA35	95mm	105mm
SECTION C & RA45	105mm	115mm
SECTION C & RA50	110mm	120mm
SECTION C & RA60	120mm	130mm
SECTION C & RA65	125mm	135mm
SECTION C & RA75	135mm	145mm
SECTION C & RA80	140mm	150mm
SECTION C & RA90	150mm	160mm
SECTION C & RA100	160mm	170mm
SECTION C & RA110	170mm	180mm
SECTION C & RA120	180mm	190mm
SECTION C & RA135	195mm	205mm
SECTION C & RA150	210mm	220mm

Lift Off Hinge

EZYJamb® lift-off hinges allow for removal of a hinged door without having to unscrew the hinges. Lift-off EZYJamb® hinges are finished in brushed stainless steel for a look with class and style, are easy to fit and time saving. Lift-off Hinges are available in both left and right handing and are recommended for internal use along with Lift-off Channel for the header which creates a deep rebate that conceals the service gap above the door.

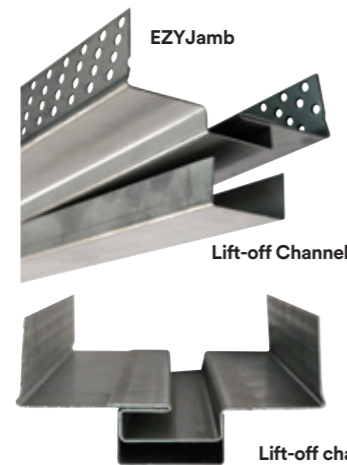

The Lift-off channel supplied is designed to fit over the header stop and affixed with construction adhesive.

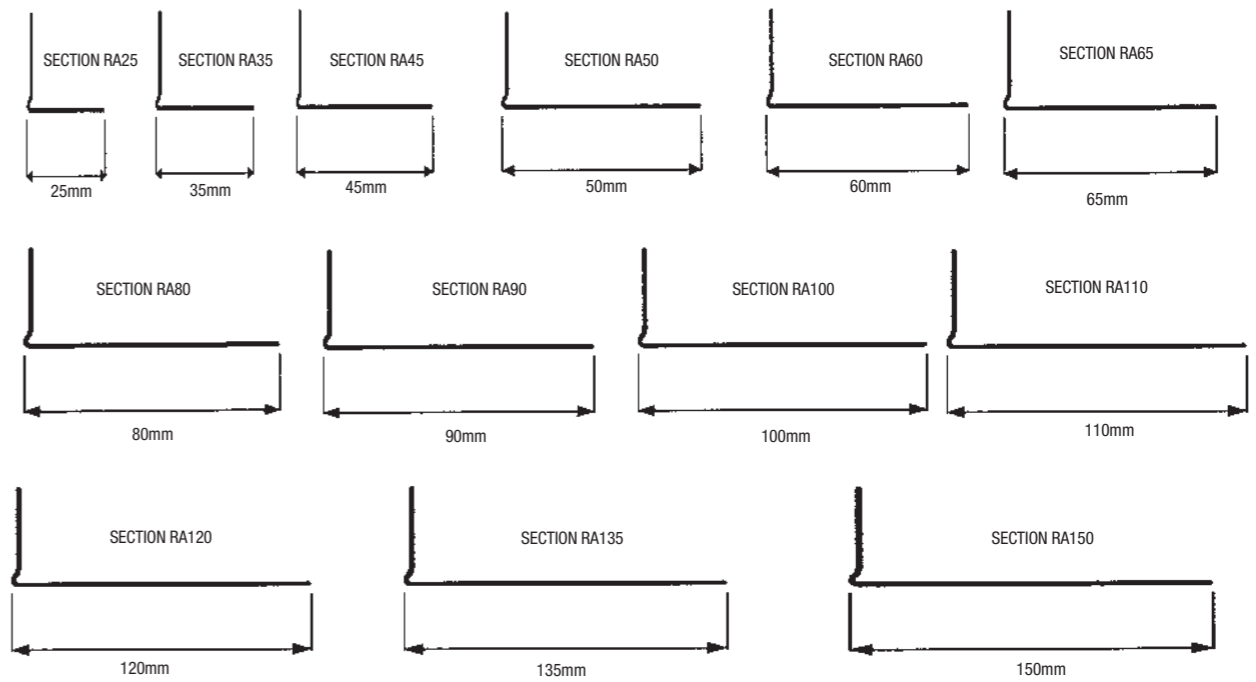
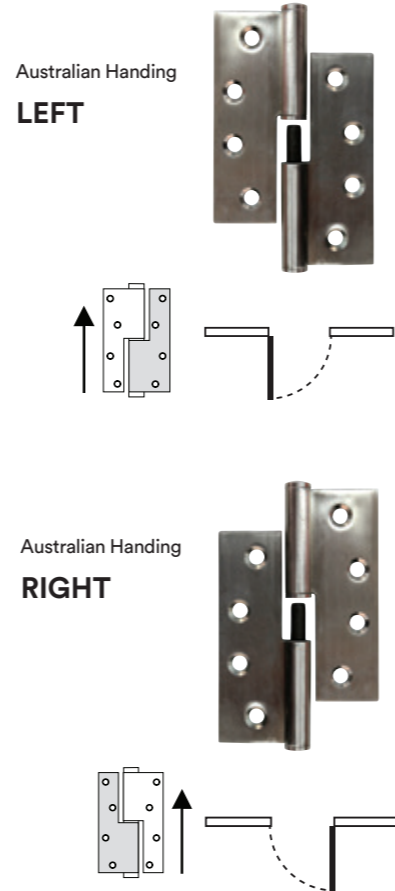

*Custom sizes to suit larger wall thicknesses available.

*LEAD TIMES APPLY

Installation Detail

EZYJamb® Ezc steel door frame adjustable for wall thicknesses up to 220mm.

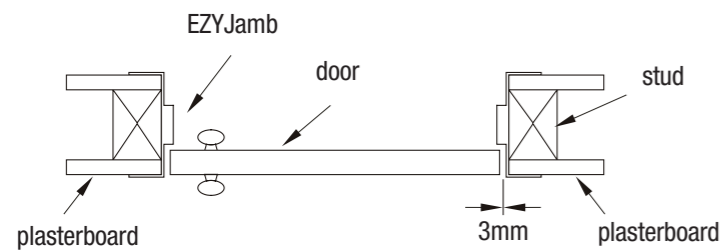

DOOR WIDTH + 15mm
PLASTERBOARD SURFACE

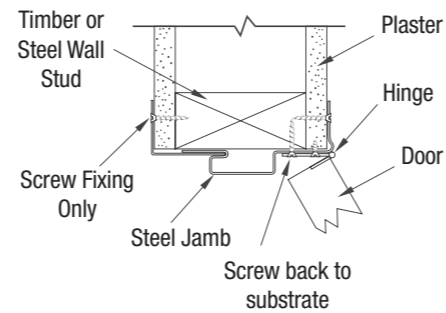
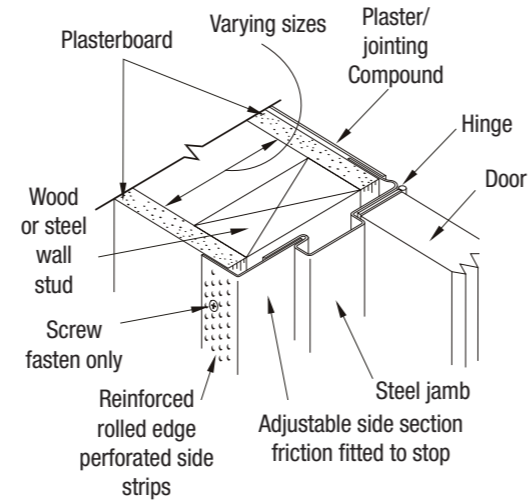
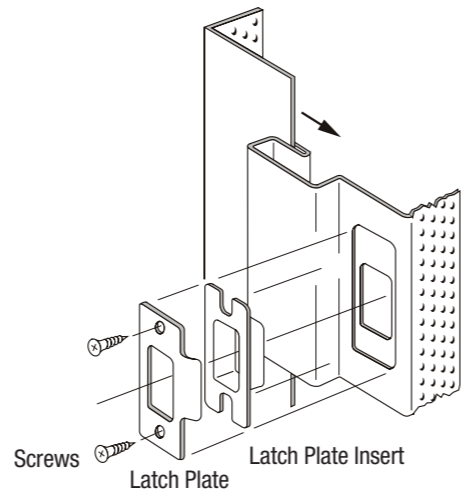
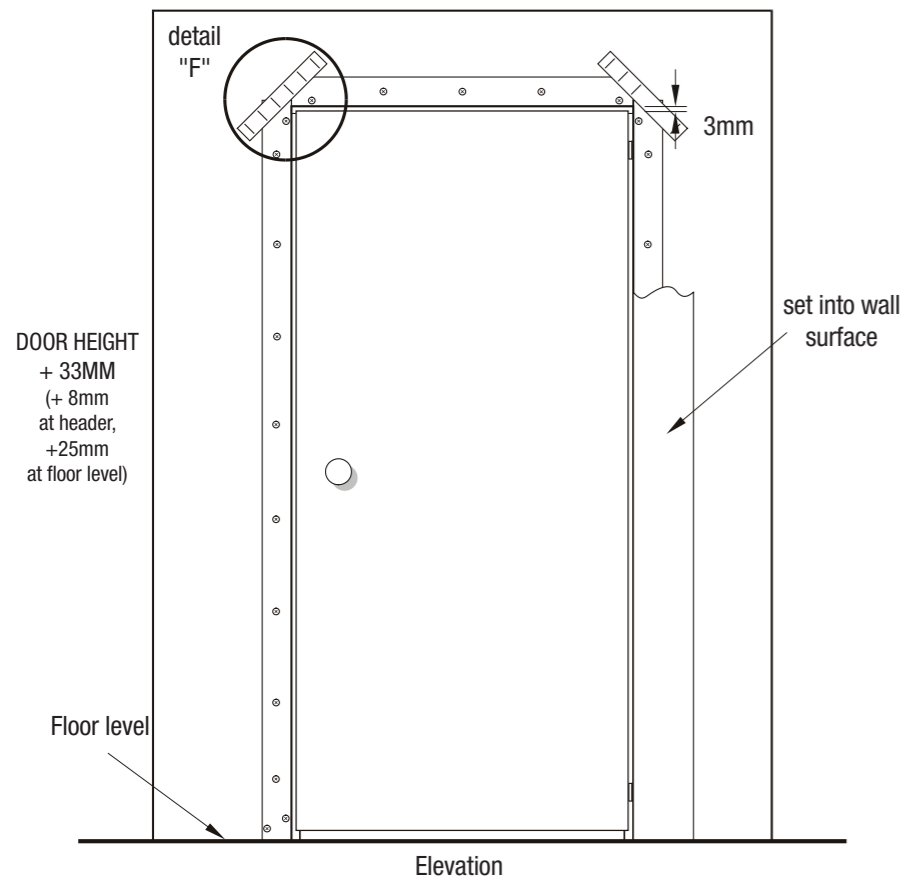

Head Installation

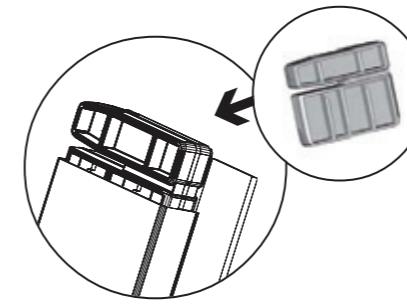

Head joiner as inserted in jamb.

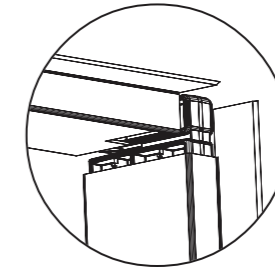

Locate head into joiner and make flush with jamb so the head joiner is not seen.

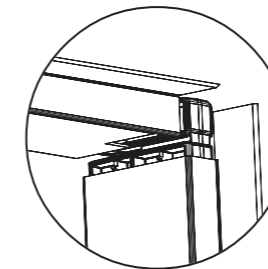

Remove the remaining head joiner out of the strike jamb into the end of the head (as shown) to receive the strike jamb.



For 35mm, 38mm and 43mm Doors

EZYJamb Ezc trimless door frame

Section C
Standard strike plate height from base of jamb to centerline frame is 1020mm

Hinges available from manufacturer
1. Invisible Type ROCyork RY-45

2. EZYJamb standard Hinges
All standard hinges are surface applied
100mm Stainless Steel (SS)

*Non stock item. Lead time applies.

Installation Videos



Convenient step by step video instructions for both the EZYJamb door frame and RocYork door hardware are available online at ezyjamb.com.au



Order Form

Both getting a quote for the EZYJamb® product, and ordering it are very simple. Just follow the Ordering Instructions and fill out the online Order Form available at the EZYJamb® website or contact sales@ezyjamb.com.au

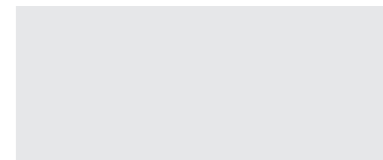
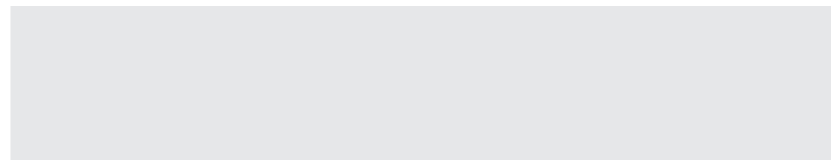
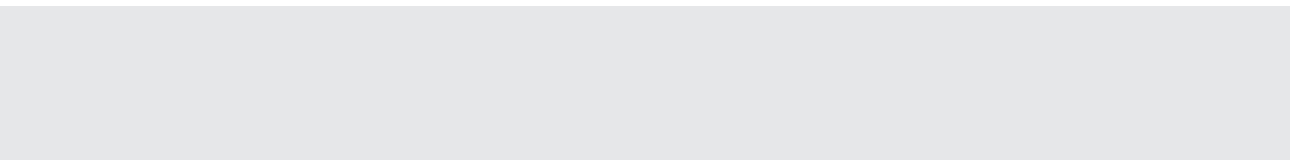
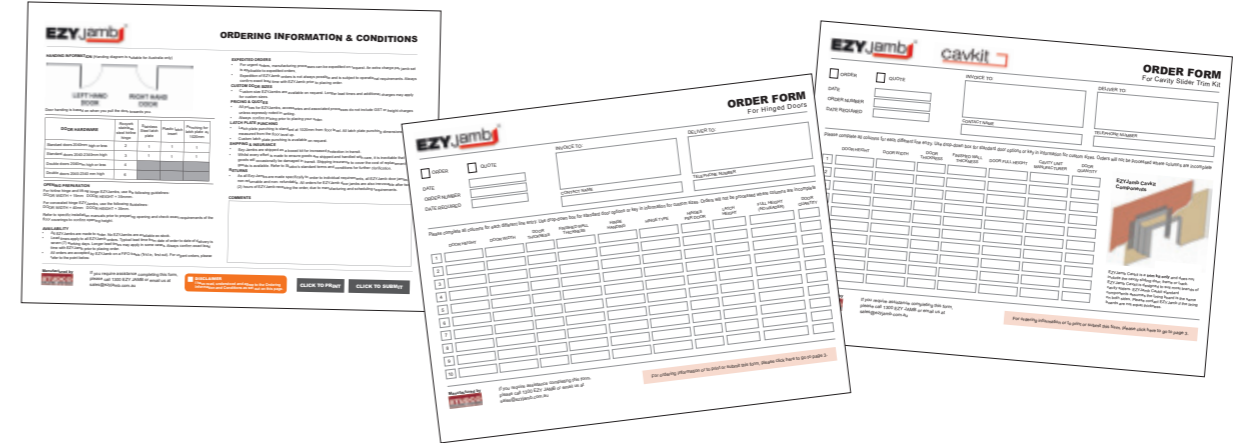

Green Star Credentials

Architects and interior designers have a unique opportunity to use EZYJamb® flush finish door jamb to achieve a modern, square-set interior without compromising the Green Star credentials for the building. EZYJamb® is made from up to 30% recycled content in steel material, it's shipped in 100% recyclable packaging, there is no wastage generated on site and it's manufactured under ISO14001 EMS policy. Talk to us today about earning Green Star points for your door jambs.



Delivery



EZ Concept USA - New York
1700 Boulter Industrial Parkway
Webster, NY 14850
Phone: 1 888 399 5262
F: 585.545.3010
E: sales@ezconcept.com
E: quotes@ezconcept.com
E: sales@rocyork.com

EZ Concept USA - Los Angeles
5450 W 83rd Street
Los Angeles, CA 90045
(By appointment only)
E: sales@ezconcept.com
E: quotes@ezconcept.com
E: sales@rocyork.com

EZ Concept Australia - Melbourne
130 - 140 Merrindale Drive,
Croydon South, VIC 3136
Phone: (03) 9737 2500
E: sales@ezconcept.com.au
W: www.ezconcept.com.au

EZ Concept United Kingdom
Carnforth Business Park
Oakwood Way, Carnforth LA5 9FD
E: sales@concept.co.uk
W: www.ezconcept.co.uk

A Studco Innovation

